

PLASMA CUTTING

The new series of Torches
without High Frequency Start

PT-20C
PT-25C
PT-40
PT-60
PTM-60
PT-80
PTM-80
PT-100
PTM-100
PT-105Plus
PTM-105Plus
ST-120
STM-120

" EASY FIT "

PTE-100H
PTE-100M
PTE-105HPlus
PTE-105MPlus
PTS-120H
PTS-120M

Registered
Community
Design

● Higher performances

● Cleaner cut

● Faster speed

TEC.MO.[®]

PLASMA CUTTING TORCHES

PT-20C**Technical Data**

Current:	10-25 Amps
Duty Cycle:	25 Amps 35%
Gas:	Air/N ₂
Gas Pressure:	30 psi (2 bar)
Gas Flow:	65 scfh (30 lpm)
Post Flow Time:	45 sec
Pilot:	Electrode to Tip (18-22A)
Ignition:	Without HF

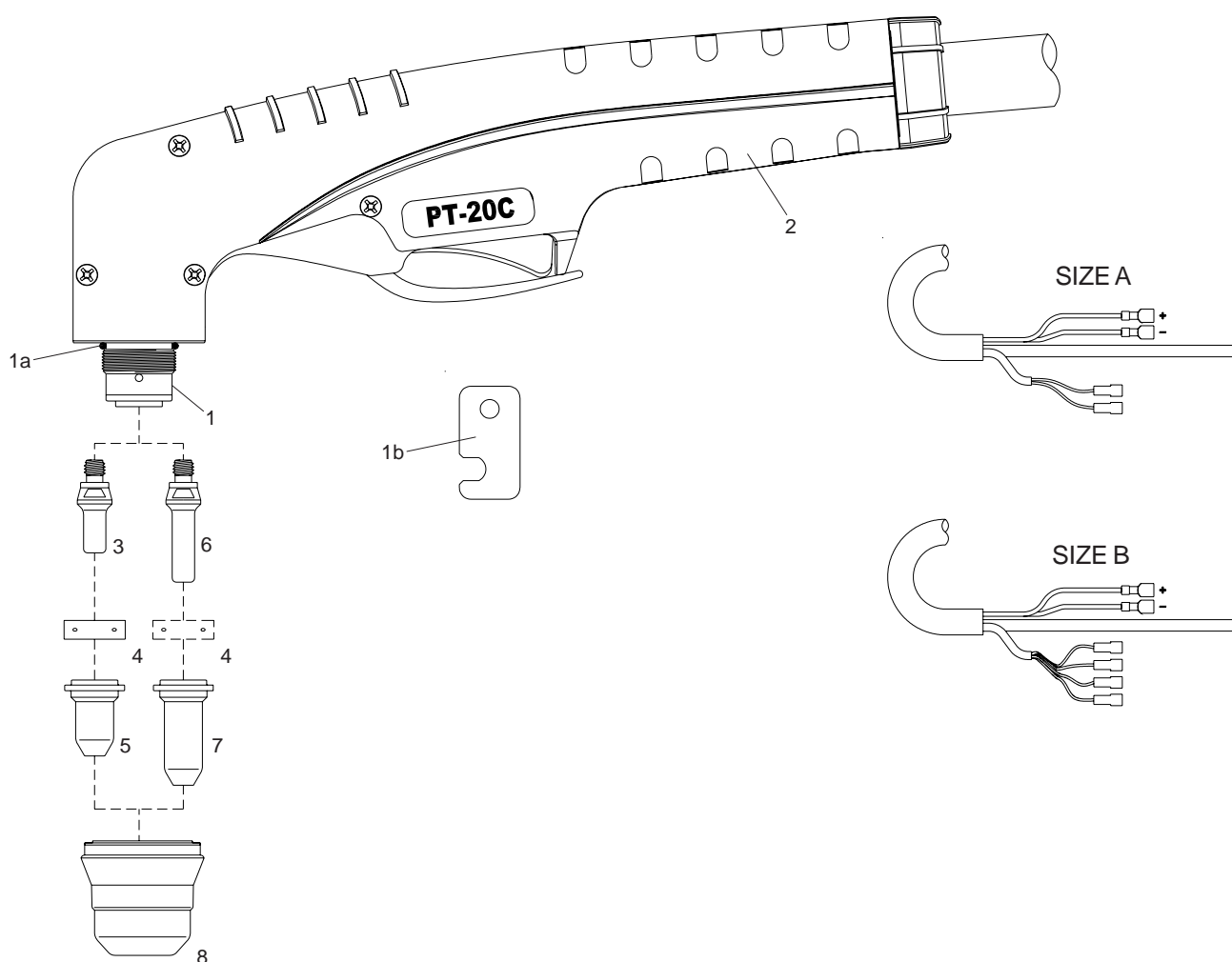

**Back Striking
Patented**



Air or N₂

PT-20C

● Standard Layout

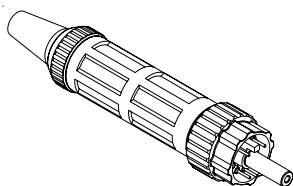
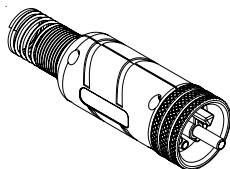
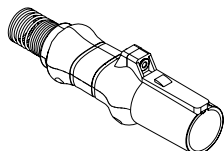
Air Filter
AT-1000Standard
Connection
Euro ConnectorEASYFIT
Connection
PatentedHY
Connection
Patent Pending

Replacement Parts

Torch parts

Item	Description	Code
1 ●	PT-20C Hand Torch Head	09600
1a	O-Ring	51620.60
1b	Wrench for electrode	09600.63
2 ●	Handle with parts	09605
3 ●	Electrode, Back Striking	52582
4 ●	Swirl ring	60028
5	Tip, Contact Cutting, \varnothing 0.65, 10-20A, Back Striking	51318.06
●	Tip, Contact Cutting, \varnothing 0.8, 20-30A, Back Striking	51318.08
6	Extended Electrode, Back Striking	52583
7	Extended Tip, Contact Cutting, \varnothing 0.65, 10-20A, Back Striking	51318L.06
	Extended Tip, Contact Cutting, \varnothing 0.8, 20-30A, Back Striking	51318L.08
8	Retaining Cap, 1 hole	60389K1
●	Retaining Cap, 2 holes	60389K
N/S ●	Wrench for electrode	60368

Torches and Leads

A	PT-20C Hand Torch, 4m (12.5 ft) Leads, Coaxial Cable	09620CX
B	PT-20C Hand Torch, 4m (12.5 ft) Leads, Coaxial Cable	09622CX

Accessories

Item	Description	Code
N/S	Circle Cutting Attachment	51866

**Torches with different cable covers
and connectors available on request.**

TEC.MO.[®]

PLASMA CUTTING TORCHES

PT-25C**Technical Data**

Current:	10-25 Amps
Duty Cycle:	25 Amps 60%
Gas:	Air/N ₂
Gas Pressure:	40 psi (2.8 bar)
Gas Flow:	85 scfh (40 lpm)
Post Flow Time:	45 sec
Pilot:	Electrode to Tip (18-22A)
Ignition:	Without HF

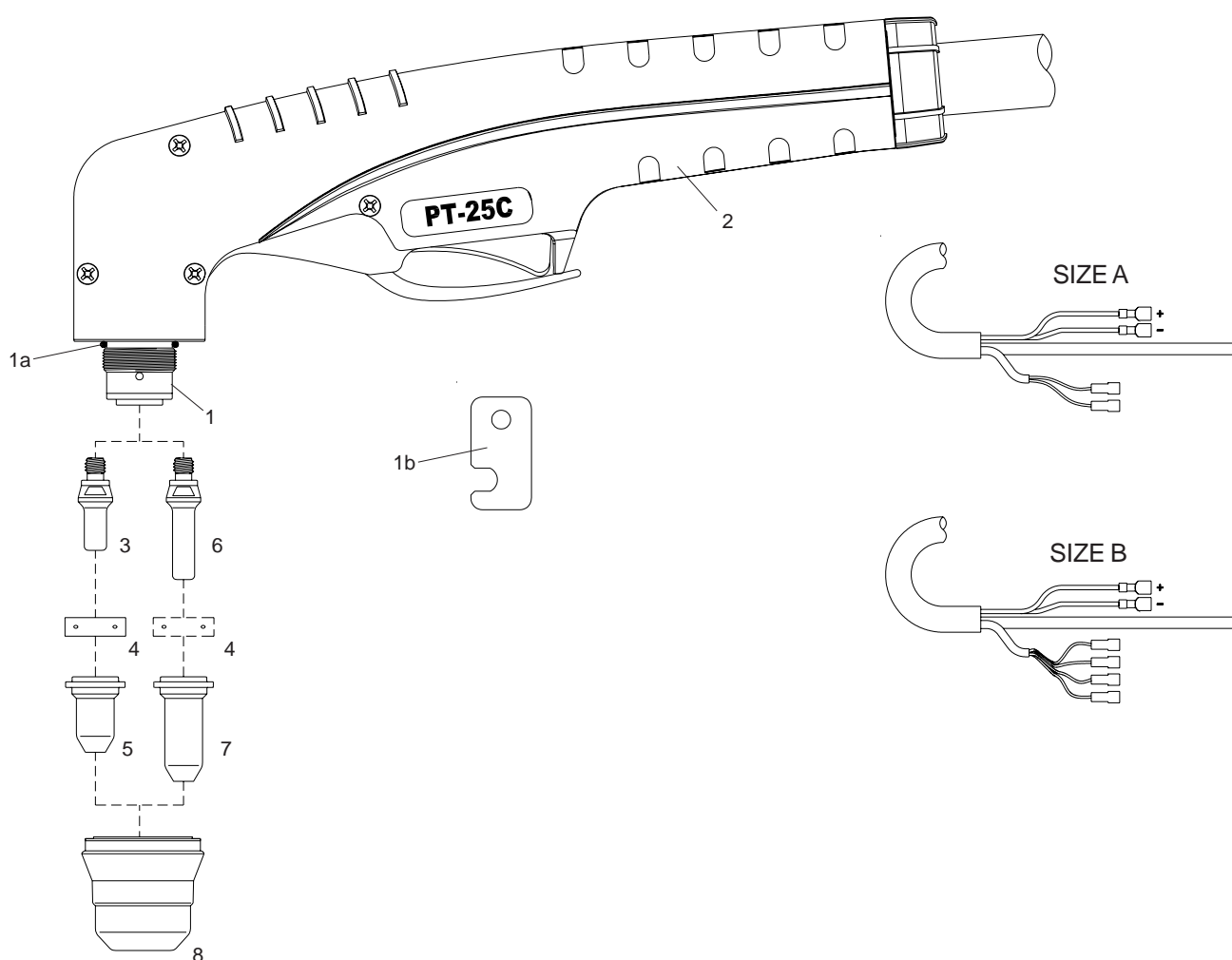

**Back Striking
Patented**

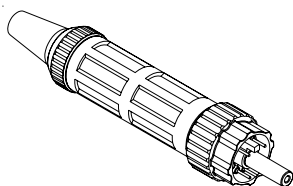
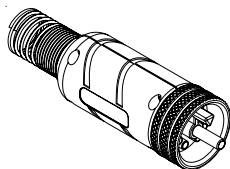
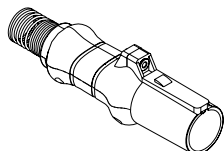

*Air or N₂***PT-25C**● **Standard Layout**Air Filter
AT-1000Standard
Connection
Euro Connector**EASYFIT**
Connection
Patented**HY**
Connection
Patent Pending**Replacement Parts****Torch parts**

Item	Description	Code
1	● PT-25C Hand Torch Head	09601
1a	O-Ring	51620.60
1b	Wrench for electrode	09600.63
2	● Handle with parts	09605
3	● Electrode, Back Striking	52582
4	● Swirl ring	60028
5	Tip, Contact Cutting, \varnothing 0.65, 10-20A, Back Striking	51318.06
	● Tip, Contact Cutting, \varnothing 0.8, 20-30A, Back Striking	51318.08
6	Extended Electrode, Back Striking	52583
7	Extended Tip, Contact Cutting, \varnothing 0.65, 10-20A, Back Striking	51318L.06
	Extended Tip, Contact Cutting, \varnothing 0.8, 20-30A, Back Striking	51318L.08
8	Retaining Cap, 1 hole	60389K1
	● Retaining Cap, 2 holes	60389K
	Retaining Cap, 4 holes	60389K4
N/S	● Wrench for electrode	60368

Torches and Leads

A	PT-25C Hand Torch, 4m (12.5 ft) Leads, Coaxial Cable	09625CX
B	PT-25C Hand Torch, 4m (12.5 ft) Leads, Coaxial Cable	09627CX

Accessories

Item	Description	Code
N/S	Circle Cutting Attachment	51866

**Torches with different cable covers
and connectors available on request.**

PLASMA CUTTING TORCHES

Technical Data

Current: 10-40 Amps
 Duty Cycle: 40 Amps 60%
 Gas: Air/N₂
 Gas Pressure: 65-75 psi (4.4-5.0 bar)
 Gas Flow: 320 scfh (150 lpm)
 Post Flow Time: 45 sec
 Pilot: Electrode to Tip (18-22A)
 Ignition: Without HF

For the correct operation please use:
 3-Ways Solenoid Valve, inside orifice
 2.3-2.7mm - (0.090-0.106 inches)

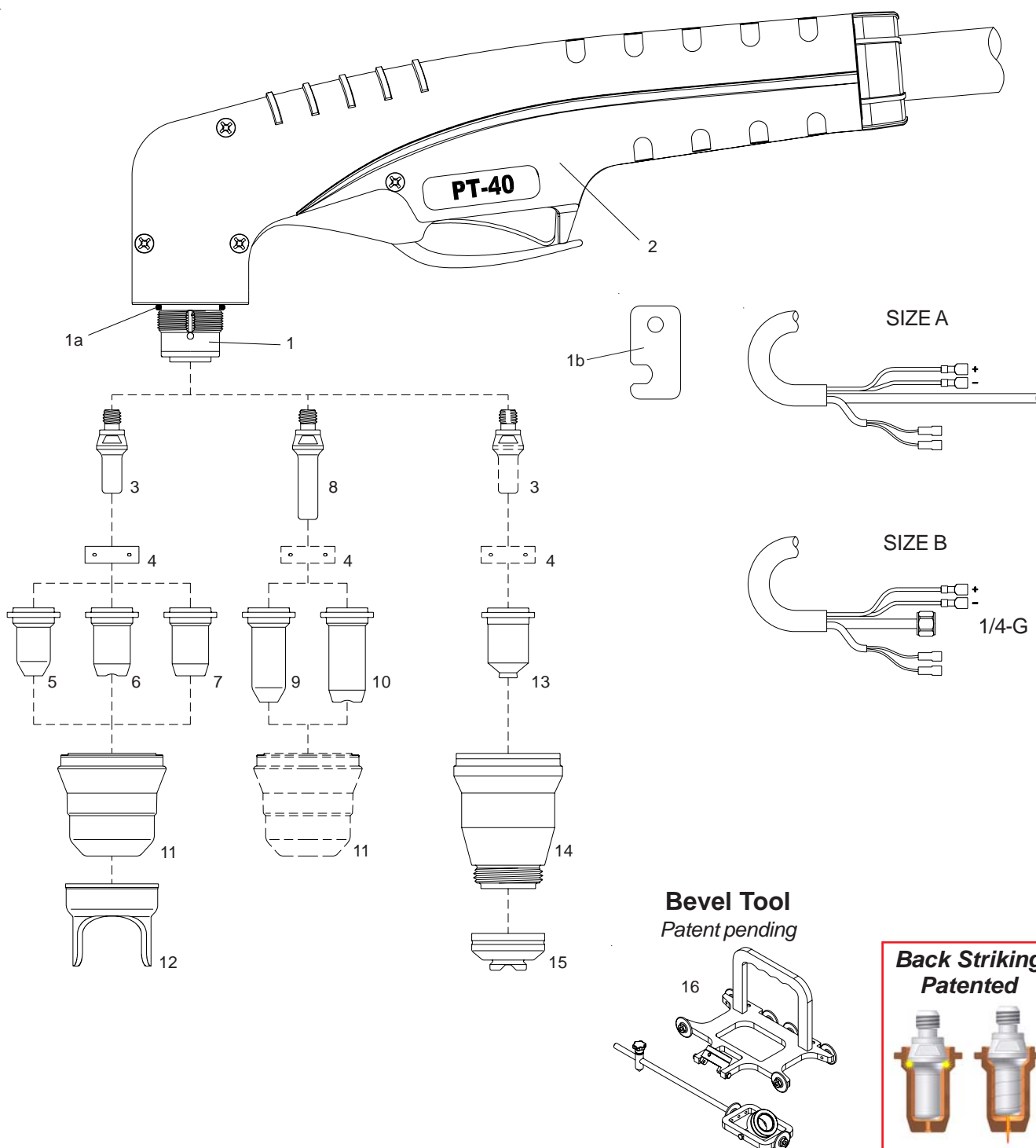

Air or N₂

PT-40

● Standard Layout

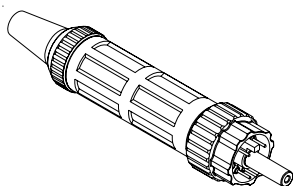
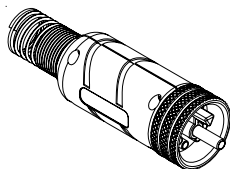
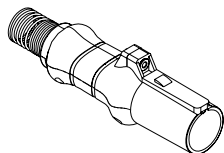
Air Filter
AT-1000Standard
Connection
Euro ConnectorEASYFIT
Connection
PatentedHY
Connection
Patent Pending

Replacement Parts

Torch parts

Item	Description	Code
1	● PT-40 Hand Torch Head	09602
1a	O-Ring	51620.60
1b	Wrench for electrode	09600.63
2	● Handle with parts	09605
3	● Electrode, Back Striking	52582
4	● Swirl ring	60028
5	Tip, Contact Cutting, \varnothing 0.65, 10-20A, Back Striking	51318.06
	Tip, Contact Cutting, \varnothing 0.8, 20-30A, Back Striking	51318.08
	● Tip, Contact Cutting, \varnothing 0.9, 30-40A, Back Striking	51318.09
6	Tip, Contact Cutting, \varnothing 0.9, 30-40A, Back Striking	51312P.09
7	Flat Tip, Cutting, \varnothing 0.9, 30-40A, Back Striking	51313P.09
	Flat Tip, Cutting, \varnothing 1.0, 40-50A, Back Striking	51313P.10
8	Extended Electrode, Back Striking	52583
9	Extended Tip, Contact Cutting, \varnothing 0.65, 10-20A, Back Striking	51318L.06
	Extended Tip, Contact Cutting, \varnothing 0.8, 20-30A, Back Striking	51318L.08
	Extended Tip, Contact Cutting, \varnothing 0.9, 30-40A, Back Striking	51318L.09
10	Extended Tip, Contact Cutting, \varnothing 0.9, 30-40A, Back Striking	51314.09
11	● Retaining Cap, 6 holes	60389
	Retaining Cap, 6 holes, Maximum Life	60389S
12	Double Pointed Spacer (for use with item 5 and 7 only)	60432
N/S	● Wrench for electrode	60368

Torches and Leads

A	PT-40 Hand Torch, 4m (12.5 ft) Leads, Coaxial Cable	09630CX
	PT-40 Hand Torch, 6m (20 ft) Leads, Coaxial Cable	09631CX
B	PT-40 Hand Torch, 4m (12.5 ft) Leads, Coaxial Cable	09632CX
	PT-40 Hand Torch, 6m (20 ft) Leads, Coaxial Cable	09633CX

Accessories

Item	Description	Code
13	Contact Tip, \varnothing 0.9, 30-40A, Back Striking	51318C.09
	Contact Tip, \varnothing 1.0, 40-50A, Back Striking	51318C.10
14	Shield Cup Body	60389C
15	Shield Cap, Hand	60485
N/S	Circle Cutting Attachment	51866
16	BEVEL TOOL (for use with extended parts)	51880

**Torches with different cable covers
and connectors available on request.**

PLASMA CUTTING TORCHES

Technical Data

Current: 10-60 Amps
 Duty Cycle: 60 Amps 80%
 Gas: Air/N2
 Gas Pressure: 65-75 psi (4.4-5.0 bar)
 Gas Flow: 320 scfh (150 lpm)
 Post Flow Time: 45 sec
 Pilot: Electrode to Tip (18-22A)
 Ignition: Without HF

For the correct operation please use:
 3-Ways Solenoid Valve, inside orifice
 2.3-2.7mm - (0.090-0.106 inches)

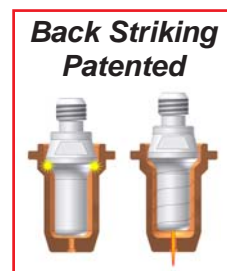
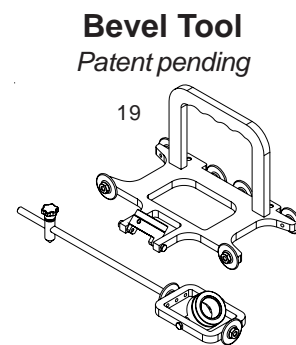
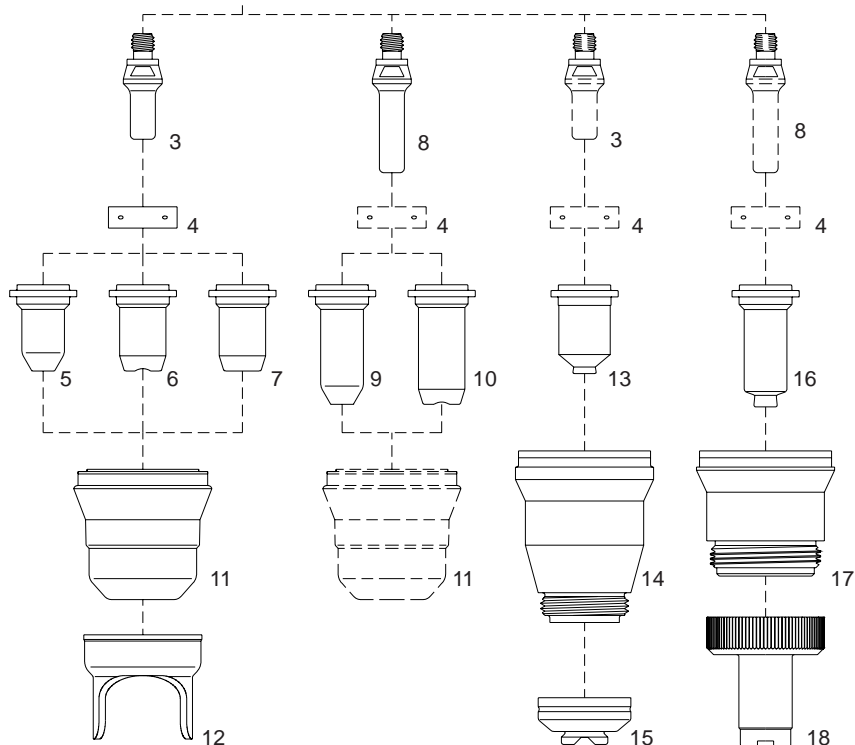
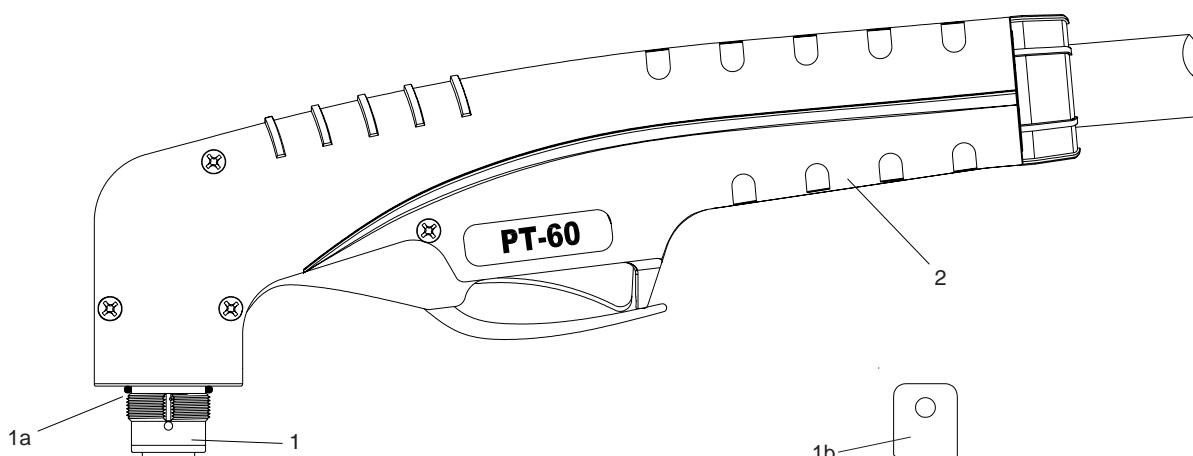

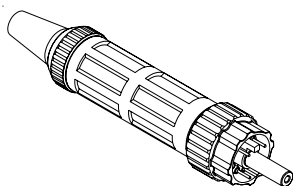
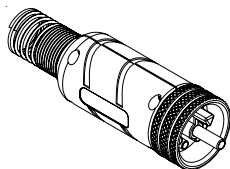
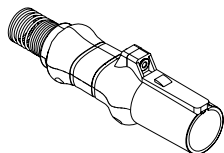
*Air or N₂***PT-60**● **Standard Layout**Air Filter
AT-1000Standard
Connection
Euro Connector**EASYFIT**
Connection
Patented**HY**
Connection
Patent Pending**Replacement Parts****Torch parts**

Item	Description	Code
1 ●	PT-60 Hand Torch Head	09603
1a	O-Ring	51620.60
1b	Wrench for electrode	09600.63
2 ●	Handle with parts	09605
3 ●	Electrode, Back Striking	52582
4 ●	Swirl ring	60028
5	Tip, Contact Cutting, \varnothing 0.65, 10-20A, Back Striking	51318.06
	Tip, Contact Cutting, \varnothing 0.8, 20-30A, Back Striking	51318.08
	Tip, Contact Cutting, \varnothing 0.9, 30-40A, Back Striking	51318.09
6	Tip, Contact Cutting, \varnothing 0.9, 30-40A, Back Striking	51312P.09
7	Flat Tip, Cutting, \varnothing 1.0, 40-50A, Back Striking	51313P.10
●	Flat Tip, Cutting, \varnothing 1.1, 50-60A, Back Striking	51313P.11
8	Extended Electrode, Back Striking	52583
9	Extended Tip, Contact Cutting, \varnothing 0.65, 10-20A, Back Striking	51318L.06
	Extended Tip, Contact Cutting, \varnothing 0.8, 20-30A, Back Striking	51318L.08
	Extended Tip, Contact Cutting, \varnothing 0.9, 30-40A, Back Striking	51318L.09
10	Extended Tip, Contact Cutting, \varnothing 0.9, 30-40A, Back Striking	51314.09
11 ●	Retaining Cap, 6 holes	60389
	Retaining Cap, 6 holes, Maximum Life	60389S
12 ●	Double Pointed Spacer (for use with item 5 and 7 only)	60432
N/S ●	Wrench for electrode	60368

Torches and Leads

PT-60 Hand Torch, 6m (20 ft) Leads, **Coaxial Cable** 09637CX

Accessories

Item	Description	Code
13	Contact Tip, \varnothing 0.9, 30-40A, Back Striking	51318C.09
	Contact Tip, \varnothing 1.0, 40-50A, Back Striking	51318C.10
	Contact Tip, \varnothing 1.1, 50-60A, Back Striking	51318C.11
14	Shield Cup Body	60389C
15	Shield Cap, Hand	60485
16	Extended Shielded Tip, \varnothing 0.9, 40A, Back Striking	51318LC.09
	Extended Shielded Tip, \varnothing 1.0, 50A, Back Striking	51318LC.10
	Extended Shielded Tip, \varnothing 1.1, 60A, Back Striking	51318LC.11
17	Shield Cup Body	60389LC
18	Extended Shield Cap 40-60A	60512L
N/S	Circle Cutting Attachment	51866
19	BEVEL TOOL (for use with extended parts)	51880

**Torches with different cable covers
and connectors available on request.**

TEC.MO.[®]

PLASMA CUTTING TORCHES

PTM-60**Technical Data**

Current:	10-60 Amps
Duty Cycle:	60 Amps 80%
Gas:	Air/N ₂
Gas Pressure:	65-75 psi (4.4-5.0 bar)
Gas Flow:	320 scfh (150 lpm)
Post Flow Time:	45 sec
Pilot:	Electrode to Tip (18-22A)
Ignition:	Without HF

For the correct operation please use:
 3-Ways Solenoid Valve, inside orifice
 2.3-2.7mm - (0.090-0.106 inches)

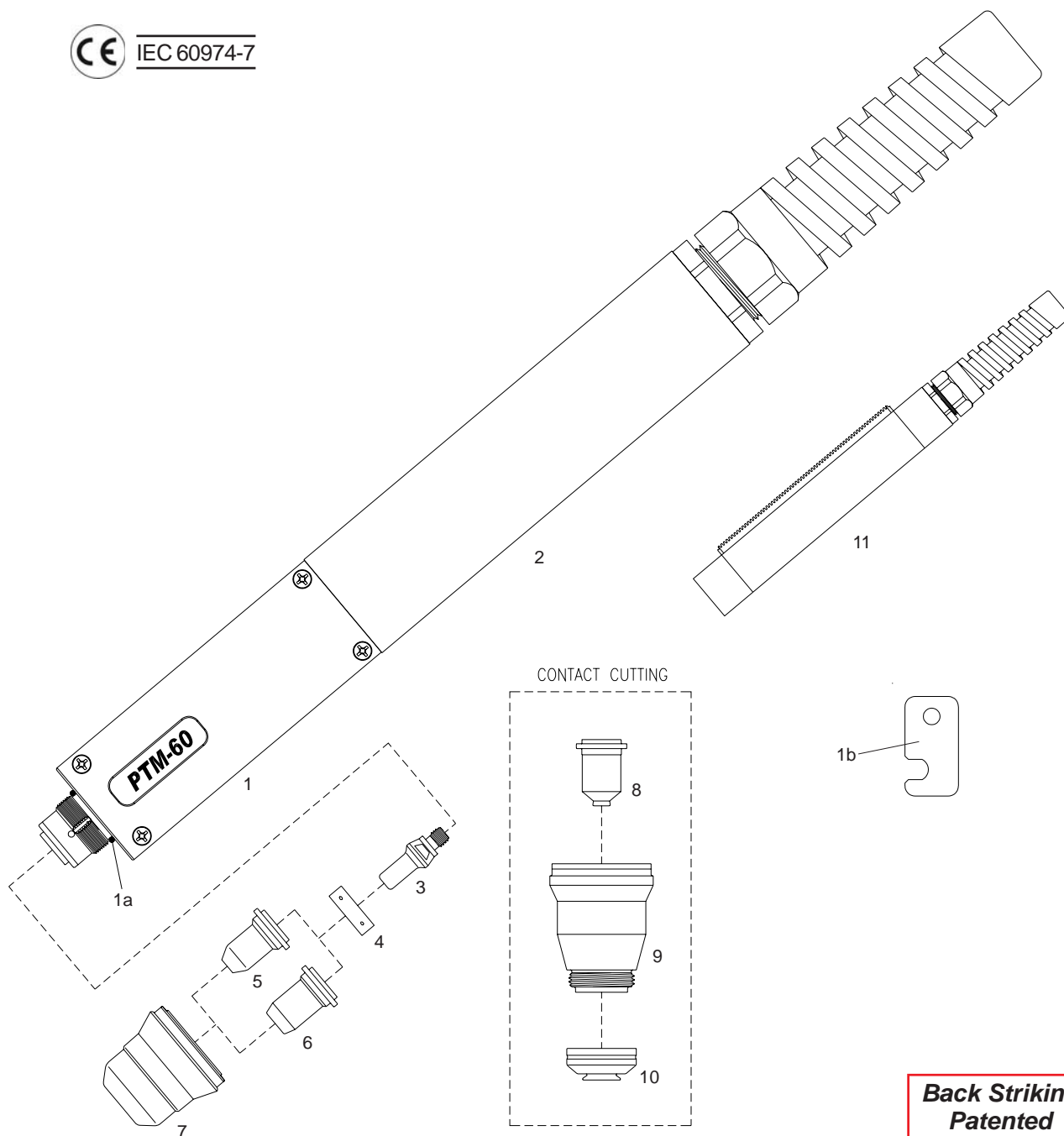

**Back Striking
Patented**



Air or N₂

PTM-60
● **Standard Layout**

Air Filter
AT-1000



Standard
Connection
Euro Connector

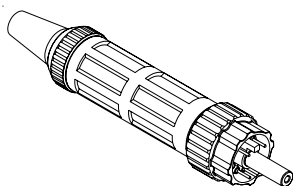

EASYFIT
Connection
Patented

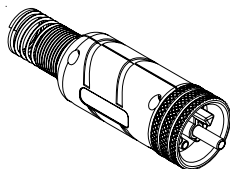

HY
Connection
Patent Pending

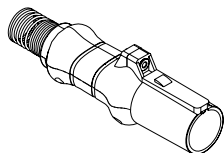

Replacement Parts

Torch parts

Item	Description	Code
1	● PTM-60 Machine Torch Head	09613
1a	O-Ring	51620.60
1b	Wrench for electrode	09600.63
2	● Fiberglass Positioning Tube	07218
3	● Electrode, Back Striking	52582
4	● Swirl ring	60028
5	Tip, Contact Cutting, \varnothing 0.65, 10-20A, Back Striking	51318.06
	Tip, Contact Cutting, \varnothing 0.8, 20-30A, Back Striking	51318.08
	Tip, Contact Cutting, \varnothing 0.9, 30-40A, Back Striking	51318.09
6	Flat Tip, Cutting, \varnothing 1.0, 40-50A, Back Striking	51313P.10
	● Flat Tip, Cutting, \varnothing 1.1, 50-60A, Back Striking	51313P.11
7	Retaining Cap, 6 holes	60389
	● Retaining Cap, 6 holes, Maximum Life	60389S
N/S	● Wrench for electrode	60368

Torches and Leads

PTM-60 Machine Torch, 6m (20 ft) Leads, Coaxial Cable	09651CX
---	---------

Accessories

Item	Description	Code
8	Contact Tip, \varnothing 0.9, 30-40A, Back Striking	51318C.09
	Contact Tip, \varnothing 1.0, 40-50A, Back Striking	51318C.10
	Contact Tip, \varnothing 1.1, 50-60A, Back Striking	51318C.11
9	Shield Cup Body	60389C
10	Shield Cap, Machine	60487
11	Fiberglass Positioning Tube with Rack	07219

**Torches with different cable covers
and connectors available on request.**

PLASMA CUTTING TORCHES

Technical Data

Current:	30-80 Amps
Duty Cycle:	80 Amps 60%
Gas:	Air/N2
Gas Pressure:	65-75 psi (4.4-5.0 bar)
Gas Flow:	340 scfh (160 lpm)
Post Flow Time:	45 sec
Pilot:	Electrode to Tip (18-22A)
Ignition:	Without HF

For the correct operation please use:
 3-Ways Solenoid Valve, inside orifice
 2.7-3.0 mm - (0.106-0.118 inches)

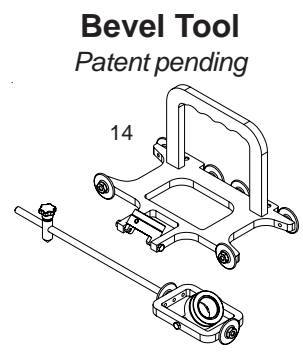
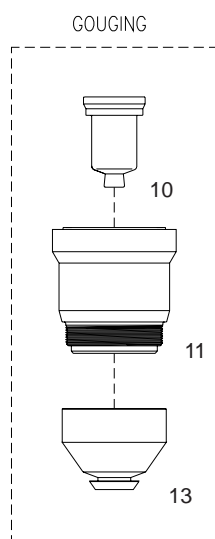
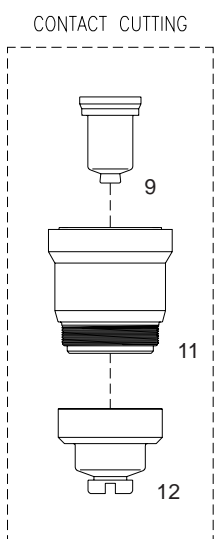
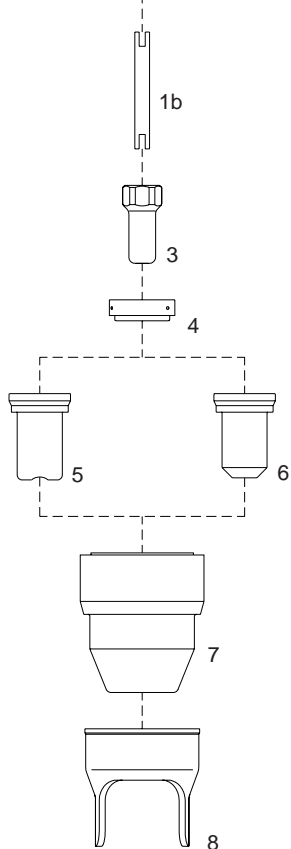
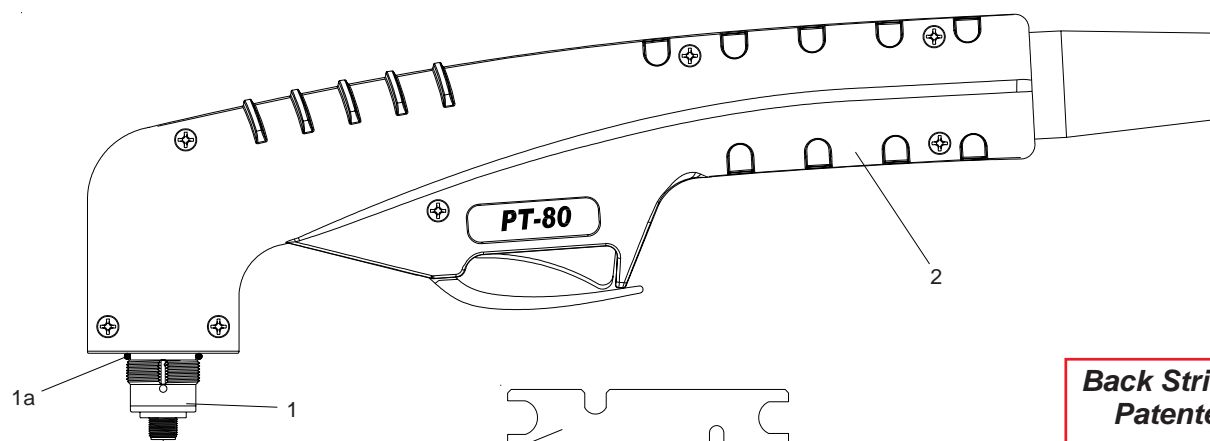

Air or N₂

PT-80
 ● **Standard Layout**

Air Filter
AT-1000



Standard
 Connection
Euro Connector

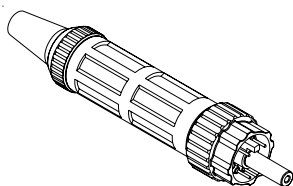

EASYFIT
 Connection
Patented

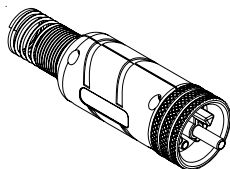

HY
 Connection
Patent Pending

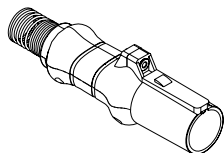

Replacement Parts

Torch parts

Item	Description	Code
1	● PT-80 Hand Torch Head	09800
1a	O-Ring	51620.60
1b	Cooling Tube	09800.42
1c	Wrench for electrode	60368
2	● Handle with parts	09705
3	● Electrode, Back Striking	52558
4	● Swirl ring	60027
5	Tip, Contact Cutting, \varnothing 0.9, 30-40A, Back Striking	51310.09
6	Tip, Cutting, \varnothing 1.0, 40-50A, Back Striking	51311.10
	Tip, Cutting, \varnothing 1.1, 50-60A, Back Striking	51311.11
	Tip, Cutting, \varnothing 1.2, 60-70A, Back Striking	51311.12
	● Tip, Cutting, \varnothing 1.3, 70-80A, Back Striking	51311.13
7	● Retaining Cap	60510
8	● Double Pointed Spacer (for use with item 6 only)	60434
N/S	● Wrench for electrode	60368

Torches and Leads

PT-80	Hand Torch, 6m (20 ft) Leads, Coaxial Cable	09821CX
PT-80	Hand Torch, 12m (40 ft) Leads, Coaxial Cable	09826CX

Accessories

Item	Description	Code
9	Contact Tip, \varnothing 1.0, 40-50A, Back Striking	51311S.10
	Contact Tip, \varnothing 1.1, 50-60A, Back Striking	51311S.11
	Contact Tip, \varnothing 1.2, 60-70A, Back Striking	51311S.12
	Contact Tip, \varnothing 1.3, 70-80A, Back Striking	51311S.13
10	Tip, Gouging, 80A, Back Striking	51311G.16
11	Shield Cup Body	60511
12	Shield Cap, Hand	60504
13	Shield Cap, Gouging	60508
N/S	Circle Cutting Attachment	51853
14	BEVEL TOOL	51880

**Torches with different cable covers
 and connectors available on request.**

TEC.MO.[®]

PLASMA CUTTING TORCHES

PTM-80**Technical Data**

Current:	40-80 Amps
Duty Cycle:	80 Amps 60%
Gas:	Air/N2
Gas Pressure:	65-75 psi (4.4-5.0 bar)
Gas Flow:	340 scfh (160 lpm)
Post Flow Time:	45 sec
Pilot:	Electrode to Tip (18-22A)
Ignition:	Without HF

For the correct operation please use:
 3-Ways Solenoid Valve, inside orifice
 2.7-3.0mm - (0.106-0.118 inches)

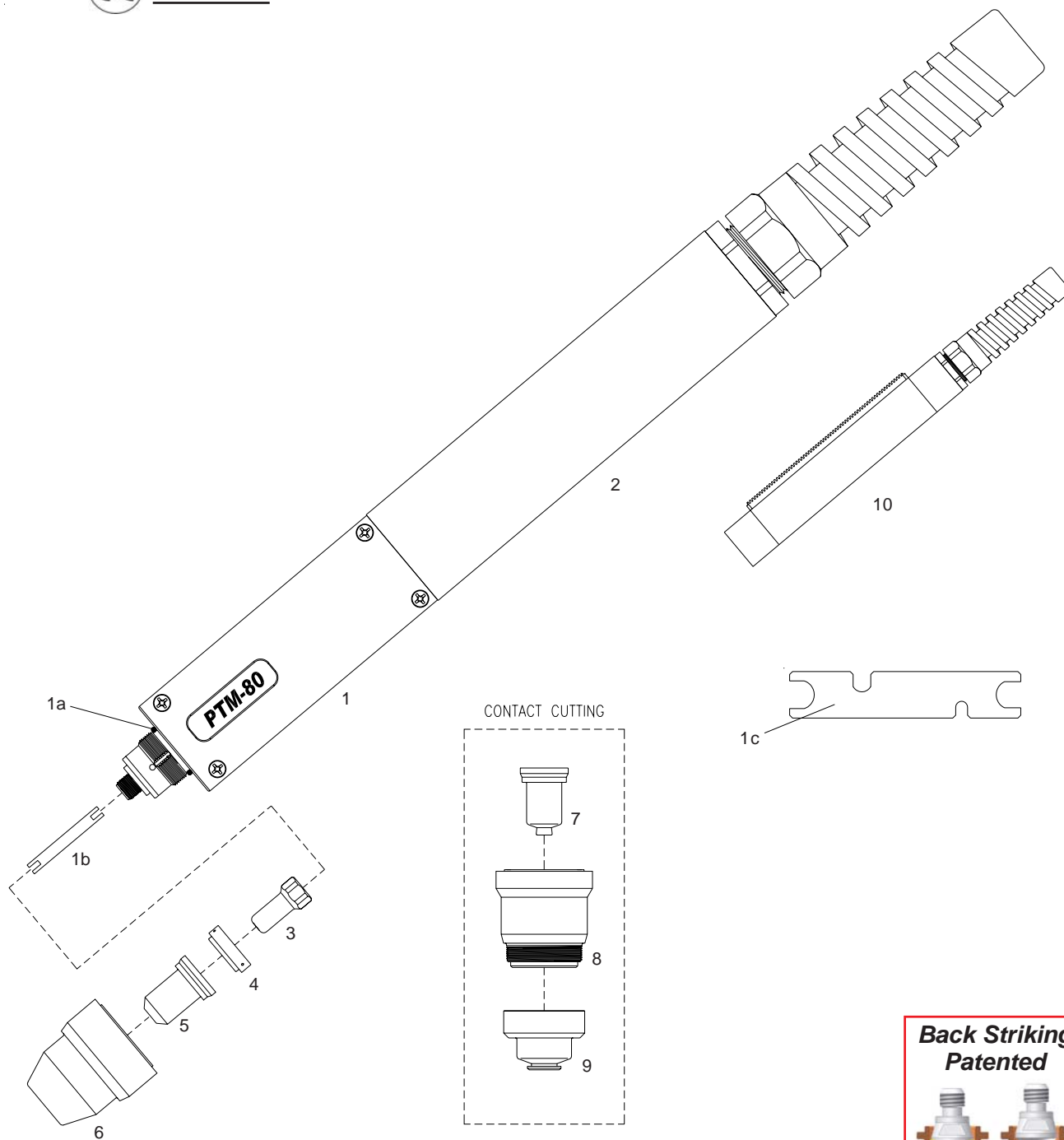

**Back Striking
Patented**



Air or N₂

PTM-80
 ● **Standard Layout**

Air Filter
AT-1000



Standard
 Connection
Euro Connector

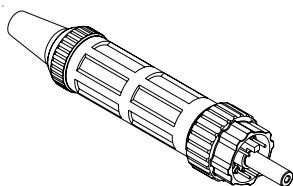

EASYFIT
 Connection
Patented

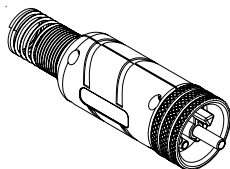

HY
 Connection
Patent Pending

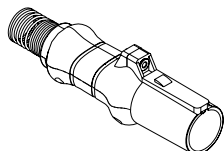

Replacement Parts

Torch parts

Item	Description	Code
1 ●	PTM-80 Machine Torch Head	09810
1a	O-Ring	51620.60
1b	Cooling Tube	09800.42
1c	Wrench for electrode	60368
2 ●	Fiberglass Positioning Tube	07218
3 ●	Electrode, Back Striking	52558
4 ●	Swirl ring	60027
5	Tip, Cutting, ø 1.0, 40-50A, Back Striking	51311.10
	Tip, Cutting, ø 1.1, 50-60A, Back Striking	51311.11
	Tip, Cutting, ø 1.2, 60-70A, Back Striking	51311.12
●	Tip, Cutting, ø 1.3, 70-80A, Back Striking	51311.13
6 ●	Retaining Cap	60510
N/S ●	Wrench for electrode	60368

Torches and Leads

PTM-80	180° Machine Torch, 6m (20 ft) Leads, Coaxial Cable	09831CX
PTM-80	180° Machine Torch, 12m (40 ft) Leads, Coaxial Cable	09836CX

Accessories

Item	Description	Code
7	Contact Tip, ø 1.0, 40-50A, Back Striking	51311S.10
	Contact Tip, ø 1.1, 50-60A, Back Striking	51311S.11
	Contact Tip, ø 1.2, 60-70A, Back Striking	51311S.12
	Contact Tip, ø 1.3, 70-80A, Back Striking	51311S.13
8	Shield Cup Body	60511
9	Shield Cap, Machine	60506
10	Fiberglass Positioning Tube with Rack	07219

**Torches with different cable covers
 and connectors available on request.**

PLASMA CUTTING TORCHES

Technical Data

Current: 30-100 Amps
 Duty Cycle: 100 Amps 60%
 Gas: Air/N2
 Gas Pressure: 70-80 psi (4.8-5.5 bar)
 Gas Flow: 510 scfh (240 lpm)
 Post Flow Time: 45 sec
 Pilot: Electrode to Tip (18-22A)
 Ignition: Without HF

For the correct operation please use:
 3-Ways Solenoid Valve, inside orifice
 3.5-4.0mm - (0.138-0.157 inches)

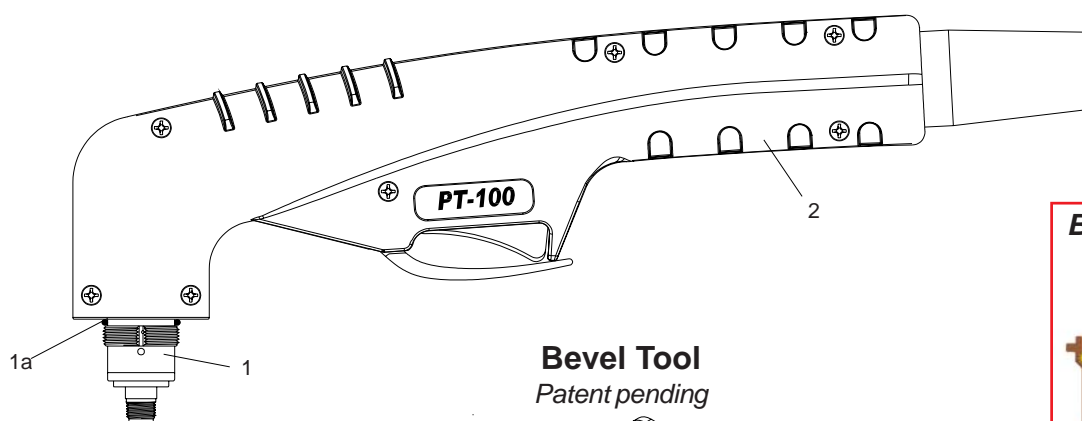
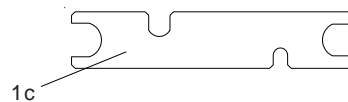

Bevel Tool
 Patent pending

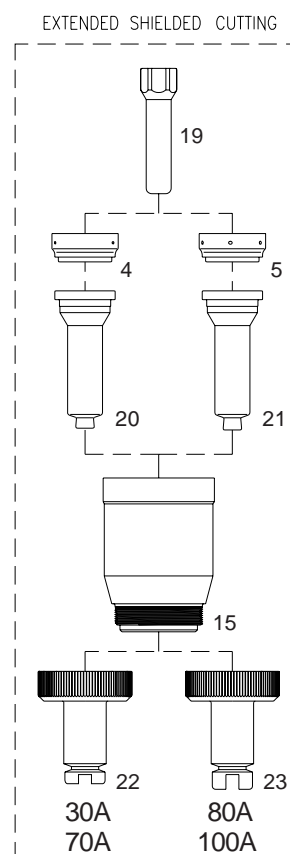
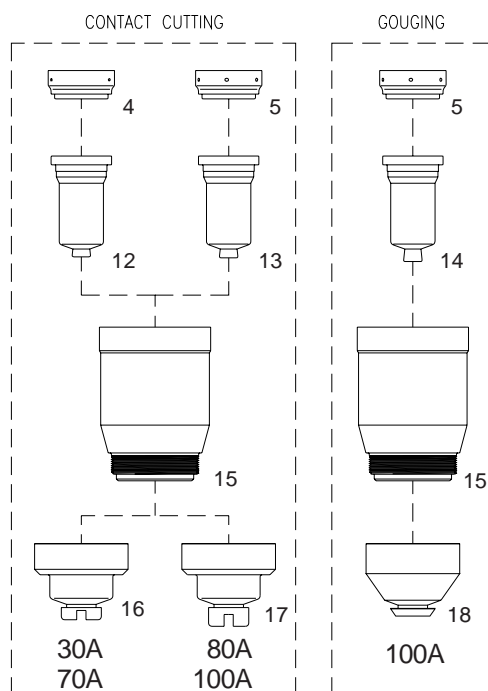
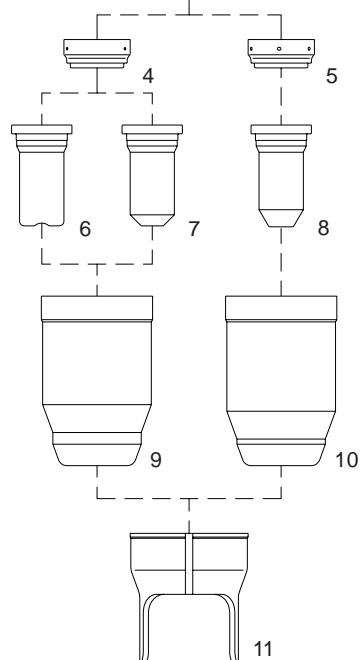
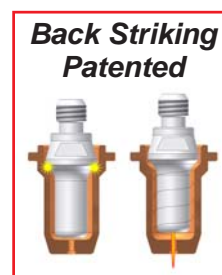
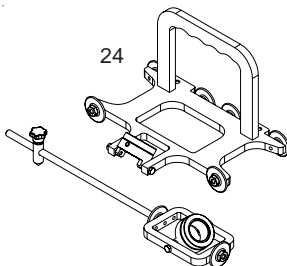

TEC.MO.®

PLASMA CUTTING TORCHES

PT-100

Air or N₂

PT-100
● Standard Layout

Air Filter
AT-1000



Standard
Connection
Euro Connector

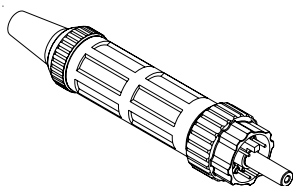

EASYFIT
Connection
Patented

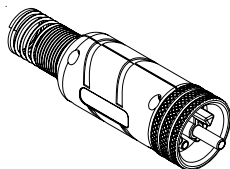

HY
Connection
Patented

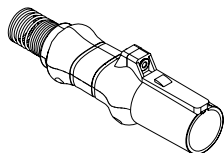

Replacement Parts

Torch parts

Item	Description	Code
1 ●	PT-100 Hand Torch Head	09700
1a	O-Ring	51190.41
1b	Cooling Tube	09700.48
1c	Wrench for electrode	60368
2 ●	Handle with parts	09705
3 ●	Electrode, Back Striking	52556
4	Swirl ring, 30-70A	60025
5 ●	Swirl ring, 80-100A and Gouging	60026
6	Tip, Contact Cutting, \varnothing 0.9, 30-40A, Back Striking	51245.09
7	Tip, Cutting, \varnothing 1.0, 40-50A, Back Striking	51246.10
	Tip, Cutting, \varnothing 1.1, 50-60A, Back Striking	51246.11
	Tip, Cutting, \varnothing 1.2, 60-70A, Back Striking	51246.12
8	Tip, Cutting, \varnothing 1.4, 80-90A, Back Striking	51248.14
	● Tip, Cutting, \varnothing 1.5, 100A, Back Striking	51248.15
9	Retaining Cap, 30-70A	60500
10 ●	Retaining Cap, 80-100A	60501
11 ●	Double Pointed Spacer (for use with item. 7 and 8 only)	60444
N/S ●	Wrench for electrode	60368

Torches and Leads

PT-100	Hand Torch, 6m (20 ft) Leads, Coaxial Cable	09721CX
PT-100	Hand Torch, 12m (40 ft) Leads, Coaxial Cable	09726CX

Accessories

Item	Description	Code
12	Contact Tip, \varnothing 1.0, 40-50A, Back Striking	51276.10
	Contact Tip, \varnothing 1.1, 50-60A, Back Striking	51276.11
	Contact Tip, \varnothing 1.2, 60-70A, Back Striking	51276.12
13	Contact Tip, \varnothing 1.4, 80-90A, Back Striking	51278.14
	Contact Tip, \varnothing 1.5, 100A, Back Striking	51278.15
14	Tip, Gouging, 100A, Back Striking	51278G.22
15	Shield Cup Body	60502
16	Shield Cap, Hand, 40-70A	60504
17	Shield Cap, Hand, 80-100A	60505
18	Shield Cap, Gouging	60508
19	Extended Electrode	52556L
20	Extended Shielded Tip, \varnothing 1.0, 40-50A,	51276L.10
	Extended Shielded Tip, \varnothing 1.1, 50-60A,	51276L.11
	Extended Shielded Tip, \varnothing 1.2, 60-70A,	51276L.12
21	Extended Shielded Tip, \varnothing 1.4, 80-90A,	51278L.14
	Extended Shielded Tip, \varnothing 1.5, 100A,	51278L.15
22	Extended Shielded Cap, Hand, 40-70A	60504L
23	Extended Shielded Cap, Hand, 80-100A	60505L
N/S	Circle Cutting Attachment	51864
24	BEVEL TOOL	51887

**Torches with different cable covers
and connectors available on request.**

PLASMA CUTTING TORCHES

Technical Data

Current:	30-100 Amps
Duty Cycle:	100 Amps 60%
Gas:	Air/N2
Gas Pressure:	70-80 psi (4.8-5.5 bar)
Gas Flow:	510 scfh (240 lpm)
Post Flow Time:	45 sec
Pilot:	Electrode to Tip (18-22A)
Ignition:	Without HF

For the correct operation please use:
 3-Ways Solenoid Valve, inside orifice
 3.5-4.0mm - (0.138-0.157 inches)

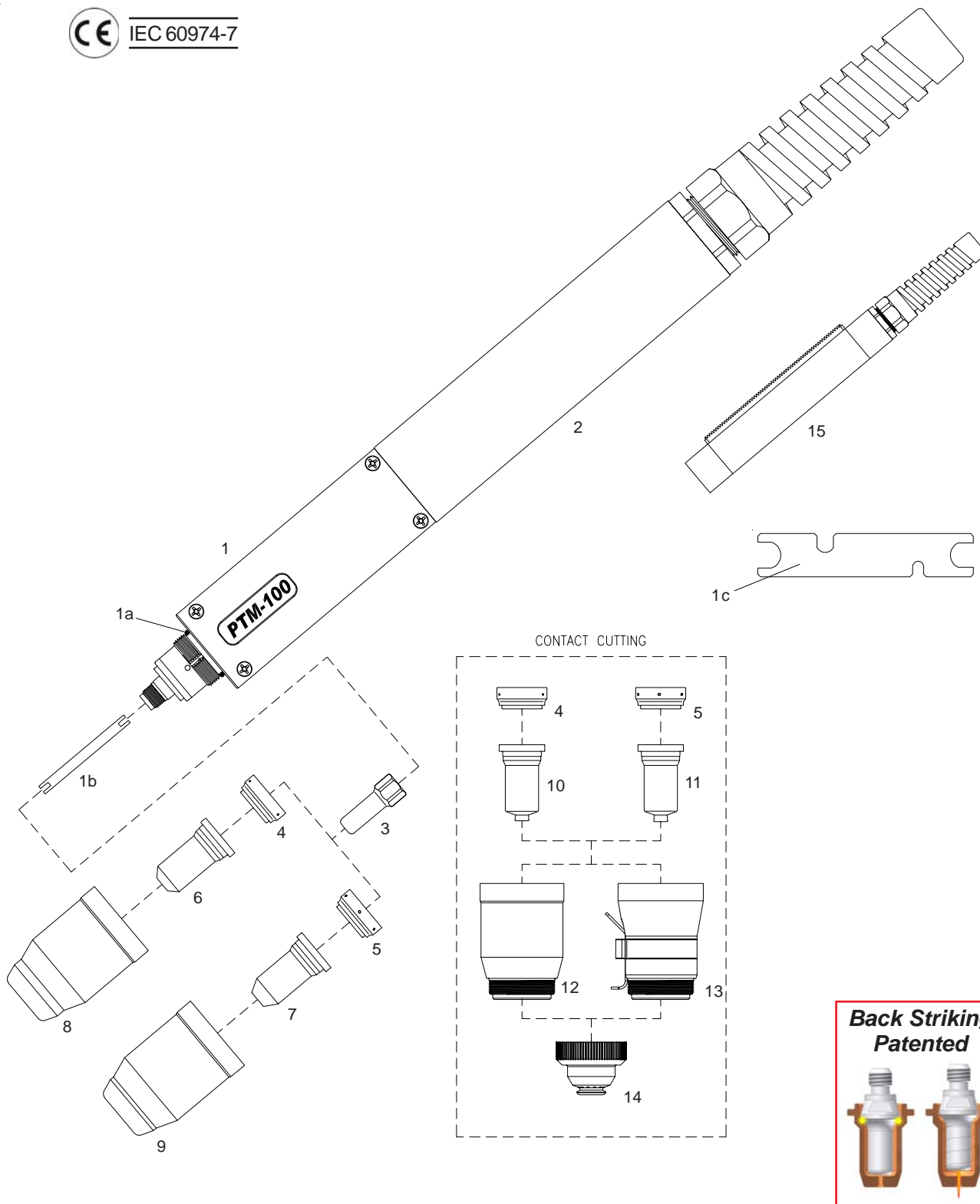

Air or N₂

PTM-100
 ● **Standard Layout**

Air Filter
AT-1000



Standard
Connection
Euro Connector

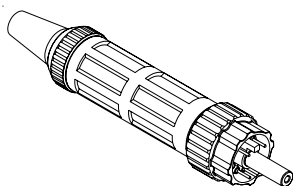

EASYFIT
Connection
Patented

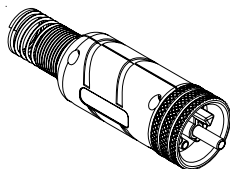

HY
Connection
Patent Pending

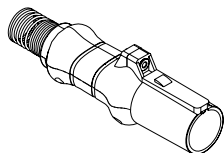

Replacement Parts

Torch parts

Item	Description	Code
1	● PTM-100 Machine Torch Head	09710
1a	O-Ring	51190.41
1b	Cooling Tube	09700.48
1c	Wrench for electrode	60368
2	● Fiberglass Positioning Tube	07218
3	● Electrode, Back Striking	52556
4	Swirl ring, 30-70A	60025
5	● Swirl ring, 80-100A	60026
6	Tip, Cutting, \varnothing 1.0, 40-50A, Back Striking	51246.10
	Tip, Cutting, \varnothing 1.1, 50-60A, Back Striking	51246.11
	Tip, Cutting, \varnothing 1.2, 60-70A, Back Striking	51246.12
7	Tip, Cutting, \varnothing 1.4, 80-90A, Back Striking	51248.14
	● Tip, Cutting, \varnothing 1.5, 100A, Back Striking	51248.15
8	Retaining Cap, 30-70A	60500
9	● Retaining Cap, 80-100A	60501
N/S	● Wrench for electrode	60368

Torches and Leads

PTM-100	180° Machine Torch, 6m (20 ft) Leads, Coaxial Cable	09731CX
PTM-100	180° Machine Torch, 12m (40 ft) Leads, Coaxial Cable	09736CX

Accessories

Item	Description	Code
10	Contact Tip, \varnothing 1.0, 40-50A, Back Striking	51276.10
	Contact Tip, \varnothing 1.1, 50-60A, Back Striking	51276.11
	Contact Tip, \varnothing 1.2, 60-70A, Back Striking	51276.12
11	Contact Tip, \varnothing 1.4, 80-90A, Back Striking	51278.14
	Contact Tip, \varnothing 1.5, 100A, Back Striking	51278.15
12	Shield Cup Body	60502
13	Shield Cup Body, OHMIC	60502H
14	Shield Cap, Machine	60506
15	Fiberglass Positioning Tube with Rack	07219

**Torches with different cable covers
 and connectors available on request.**

PLASMA CUTTING TORCHES

Technical Data

Current: 30-100 Amps
 Duty Cycle: 100 Amps 60%
 Gas: Air/N2
 Gas Pressure: 70-80 psi (4.8-5.5 bar)
 Gas Flow: 510 scfh (240 lpm)
 Post Flow Time: 45 sec
 Pilot: Electrode to Tip (18-22A)
 Ignition: Without HF

For the correct operation please use:
 3-Ways Solenoid Valve, inside orifice
 3.5-4.0mm - (0.138-0.157 inches)

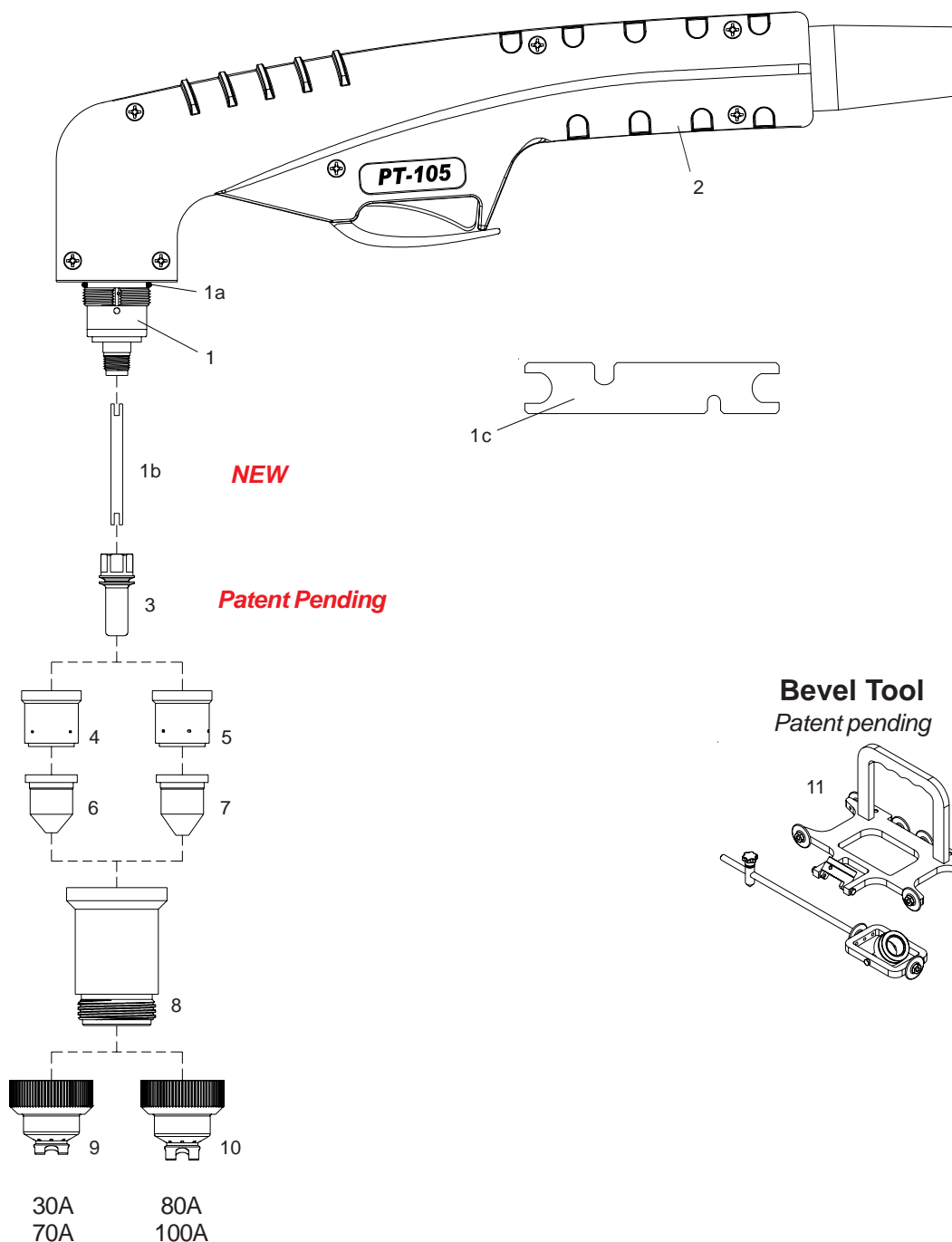

TEC.MO.[®]

PLASMA CUTTING TORCHES

PT-105Plus*Air or N₂*

PT-105Plus
 ● **Standard Layout**

Air Filter
AT-1000



Standard
 Connection
Euro Connector

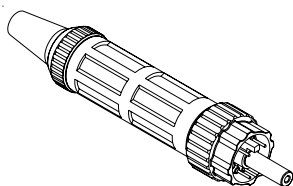

EASYFIT
 Connection
Patented

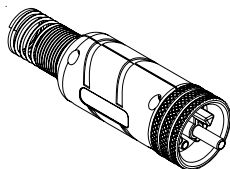

HY
 Connection
Patent Pending

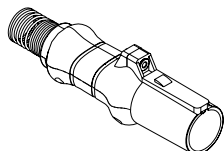

Replacement Parts

Torch parts

Item	Description	Code
1	● PT-105 Plus Hand Torch Head	09700P
1a	O-Ring	51190.41
1b	Cooling Tube, NEW	09700.62
1c	Wrench for electrode	60368
2	● Handle with parts	09705
3	● Electrode	52559
4	Swirl ring, 30-70A	60021
5	● Swirl ring, 80-100A	60022
6	Tip, Cutting, 40A	51257.09
	Tip, Cutting, 60A	51257.11
7	Tip, Cutting, 80A	51258.13
	● Tip, Cutting, 100A	51258.15
8	● Shield Cup Body	60499
9	Shield Cap, Hand, 30-70A	60514
10	● Shield Cap, Hand, 80-100A	60515
N/S	● Wrench for electrode	60368

Torches and Leads

PT-105 Plus Hand Torch, 6m (20 ft) Leads, Coaxial Cable	09721PX
PT-105 Plus Hand Torch, 12m (40 ft) Leads, Coaxial Cable	09726PX

Accessories

N/S	Circle Cutting Attachment	51865
11	BEVEL TOOL	51880

**Torches with different cable covers
 and connectors available on request.**

Technical Data

Current: 30-100 Amps
 Duty Cycle: 100 Amps 60%
 Gas: Air/N2
 Gas Pressure: 70-80 psi (4.8-5.5 bar)
 Gas Flow: 510 scfh (240 lpm)
 Post Flow Time: 45 sec
 Pilot: Electrode to Tip (18-22A)
 Ignition: Without HF

For the correct operation please use:
 3-Ways Solenoid Valve, inside orifice
 3.5-4.0mm - (0.138-0.157 inches)

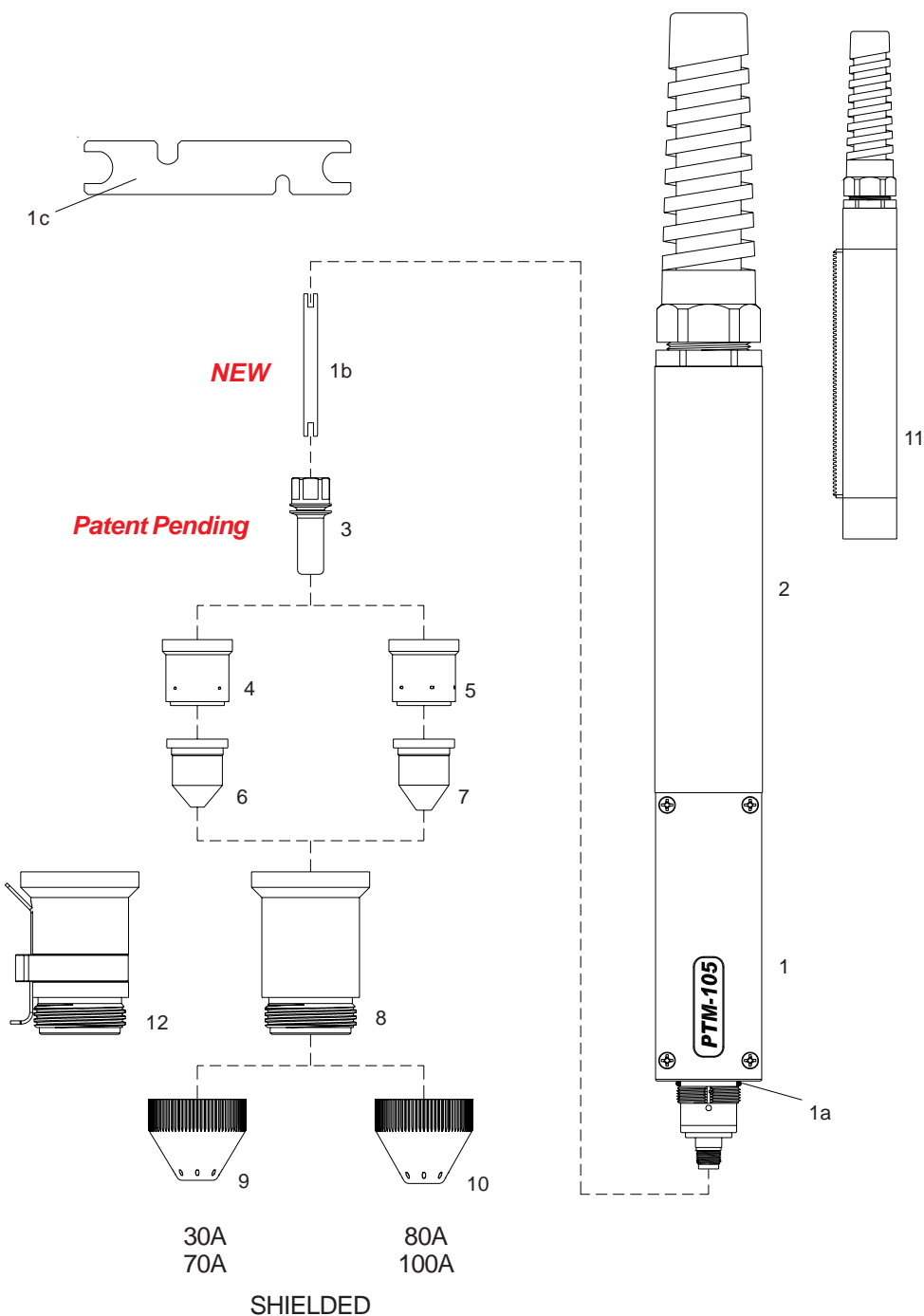

Air or N₂

PTM-105Plus
 ● **Standard Layout**

Air Filter
AT-1000



Standard
 Connection
Euro Connector

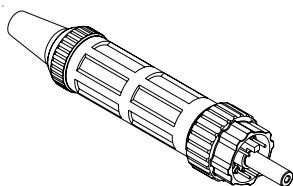

EASYFIT
 Connection
Patented

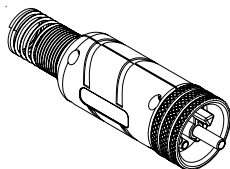

HY
 Connection
Patent Pending

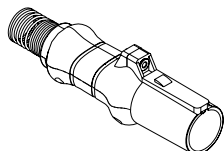

Replacement Parts

Torch parts

Item	Description	Code
1	● PTM-105 Machine Torch Head	09710P
1a	O-Ring	51190.41
1b	Cooling Tube, NEW	09700.62
1c	Wrench for electrode	60368
2	● Fiberglass Positioning Tube	07218
3	● Electrode	52559
4	Swirl ring, 30-70A	60021
5	● Swirl ring, 80-100A	60022
6	Tip, Cutting, 40A	51257.09
	Tip, Cutting, 60A	51257.11
7	Tip, Cutting, 80A	51258.13
	● Tip, Cutting, 100A	51258.15
8	● Shield Cup Body	60499
9	Shield Cap, Machine, 30-70A	60516
10	● Shield Cap, Machine, 80-100A	60517
N/S	● Wrench for electrode	60368

Torches and Leads

PTM-105	180° Machine Torch, 6m (20 ft) Leads, Coaxial Cable	09731PX
PTM-105	180° Machine Torch, 12m (40 ft) Leads, Coaxial Cable	09736PX

Accessories

11	Fiberglass Positioning Tube With Rack	07219
12	Shield Cup Body, OHMIC	60499H

**Torches with different cable covers
 and connectors available on request.**

PLASMA CUTTING TORCHES

Technical Data

Current: 40-120 Amps
 Duty Cycle: 120 Amps 60%
 Gas: Air/N2
 Gas Pressure: 72-87 PSI (5.0-6.0 bar)
 Gas Flow: 630 SCFH (295 lpm)
 Post Flow Time: 45 sec
 Pilot: Electrode to Tip (18-22A)
 Ignition: Without HF

For the correct operation please use:
 3-Ways Solenoid Valve, inside orifice
 4.5-5.5mm - (0.178-0.217 inches)

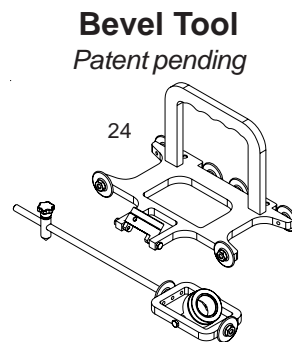
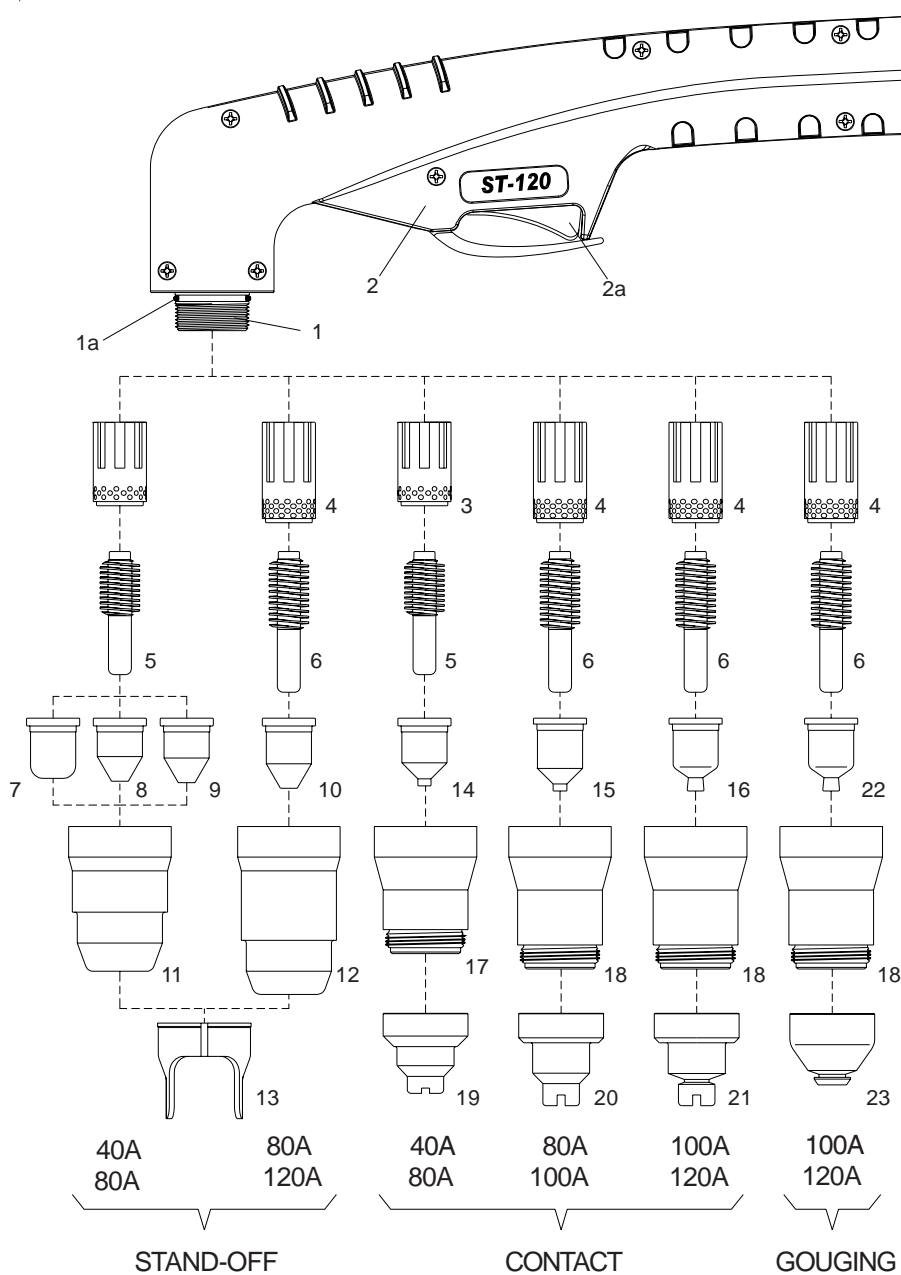

TEC.MO.[®]

PLASMA CUTTING TORCHES

ST-120*Air or N₂*

ST-120
 ● **Standard Layout**

Air Filter
AT-1000



Standard
 Connection
Euro Connector

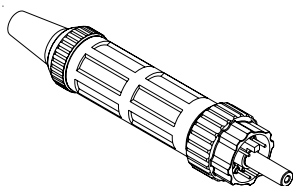

EASYFIT
 Connection
Patented

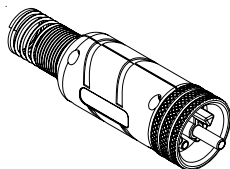

HY
 Connection
Patent Pending

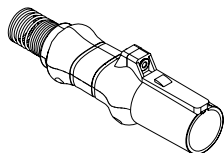

Replacement Parts

Torch parts

Item	Description	Code
1	● ST-120 Hand Torch Head	03800
1a	O-Ring	02800.60
2	● Handle with Switch	09705
2a	● Switch	07301.20
3	Swirl ring, 40-80A	60043E
	Swirl ring, 40-80A Maximum Life	60043
4	● Swirl ring, 80-120A	60044E
	Swirl ring, 80-120A Maximum Life	60044
5	Electrode, 40-80A	52675
6	● Electrode, 80-120A	52676
7	Tip, Cutting, 40A	51402
8	Tip, Cutting, 60A	51403
9	Tip, Cutting, 80A	51404
10	Tip, Cutting, 100A	51408
	● Tip, Cutting, 120A	51408T
11	Retaining Cap, 40-80A	60493
12	● Retaining Cap, 80-120A	60494
13	● Double Pointed Spacer	60434
14	Contact Tip, Cutting, 40A	51405.10
	Contact Tip, Cutting, 60A	51405.12
	Contact Tip, Cutting, 80A	51405.14
15	Contact Tip, Cutting, 100A	51406
16	Contact Tip, Cutting, 120A	51406T
17	Shield Cup Body, 40-80A	60495
18	Shield Cup Body, 80-120A	60496
19	Shield Cap, Hand, 40-80A	51981/TD
20	Shield Cap, Hand, 80-100A	51983/TD
21	Shield Cap, Hand, 100-120A	51988
22	Contact Tip, Gouging, 100-120A	51409.24
23	Shield Cap, Gouging, 100-120A	51989G

Torches and Leads

ST-120	Hand Torch, 6m (20 ft) Leads, Coaxial Cable	03821CX
ST-120	Hand Torch, 12m (40 ft) Leads, Coaxial Cable	03826CX
ST-120	Lead Assembly, Hand, 6m (20 ft) Length, Coaxial Cable	09781CX
ST-120	Lead Assembly, Hand, 12m (40 ft) Length, Coaxial Cable	09786CX

Accessories

N/S	Circle Cutting Attachment	51865
24	BEVEL TOOL	51880

**Torches with different cable covers
 and connectors available on request.**

PLASMA CUTTING TORCHES

Technical Data

Current: 40-120 Amps
 Duty Cycle: 120 Amps 60%
 Gas: Air/N2
 Gas Pressure: 72-87 PSI (5.0-6.0 bar)
 Gas Flow: 630 SCFH (295 lpm)
 Post Flow Time : 45 sec
 Pilot: Electrode to Tip **(18-22A)**
 Ignition: Without HF

For the correct operation please use:
 3-Ways Solenoid Valve, inside orifice
 4.5-5.5mm - (0.178-0.217 inches)

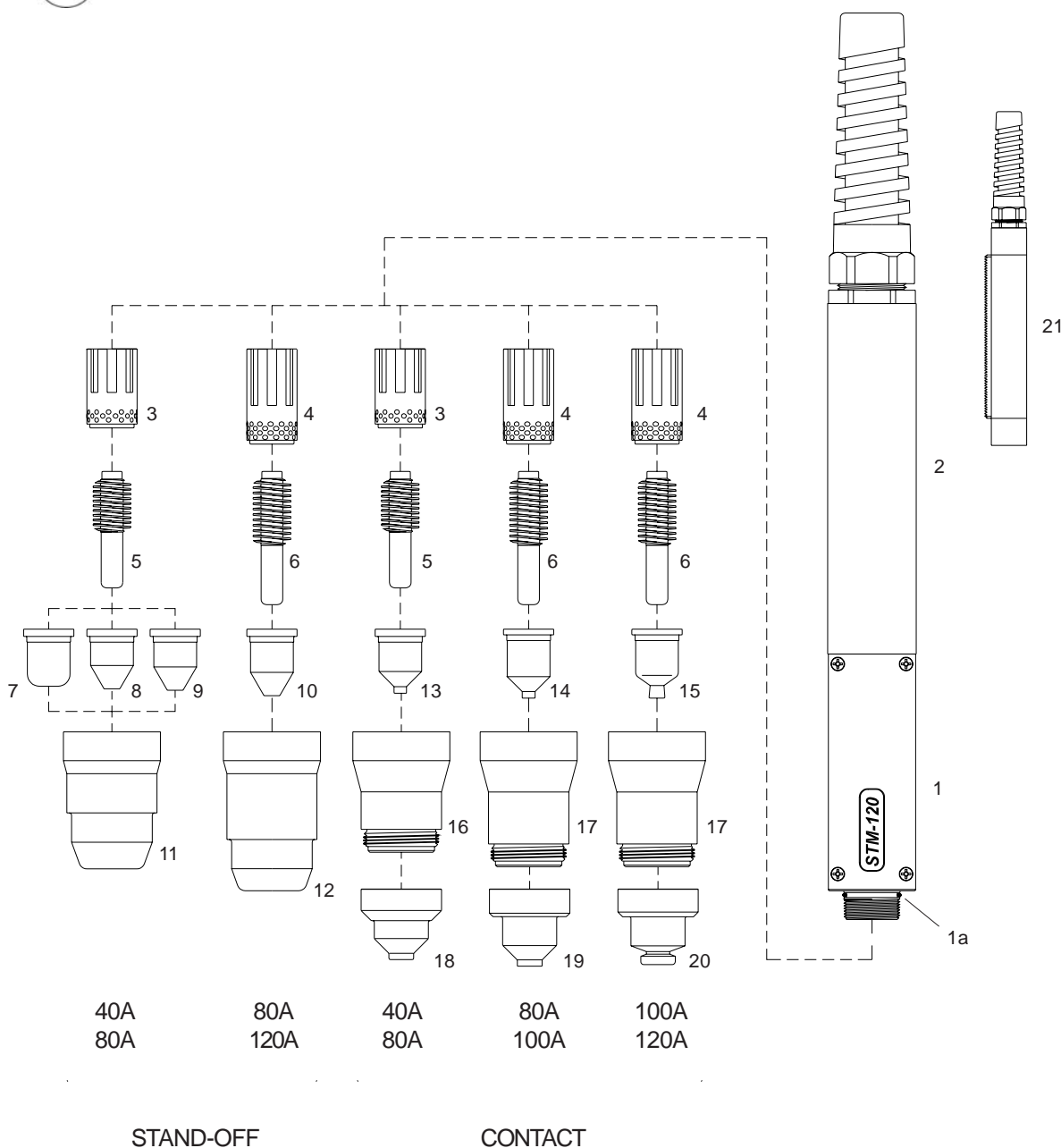

TEC.MO.[®]

PLASMA CUTTING TORCHES

STM-120*Air or N₂*

STM-120
● **Standard Layout**

Air Filter
AT-1000



Standard
Connection
Euro Connector

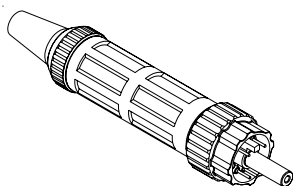

EASYFIT
Connection
Patented

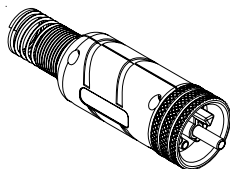

HY
Connection
Patent Pending

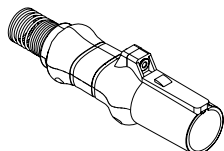
**Replacement Parts****Torch parts**

<i>Item</i>	<i>Description</i>	<i>Code</i>
1	● STM-120 Machine Torch Head	03810
1a	O-Ring	02800.60
2	● Fiberglass Positioning Tube	07218
3	Swirl ring, 40-80A	60043E
	Swirl ring, 40-80A Maximum Life	60043
4	● Swirl ring, 80-120A	60044E
	Swirl ring, 80-120A Maximum Life	60044
5	Electrode, 40-80A	52675
6	● Electrode, 80-120A	52676
7	Tip, Cutting, 40A	51402
8	Tip, Cutting, 60A	51403
9	Tip, Cutting, 80A	51404
10	Tip, Cutting, 100A	51408
	Tip, Cutting, 120A	51408T
11	Retaining Cap, 40-80A	60493
12	Retaining Cap, 80-120A	60494
13	Contact Tip, Cutting, 40A	51405.10
	Contact Tip, Cutting, 60A	51405.12
	Contact Tip, Cutting, 80A	51405.14
14	Contact Tip, Cutting, 100A	51406
15	● Contact Tip, Cutting, 120A	51406T
16	Shield Cup Body, 40-80A	60495
17	● Shield Cup Body, 80-120A	60496
18	Shield Cap, Machine, 40-80A	51982/TD
19	Shield Cap, Machine, 80-100A	51984/TD
20	● Shield Cap, Machine, 100-120A	51989

Torches and Leads

STM-120 Machine Torch, 6m (20 ft) Leads, Coaxial Cable	03831CX
STM-120 Machine Torch, 12m (40 ft) Leads, Coaxial Cable	03836CX
STM-120 Lead Assembly, Machine, 6m (20 ft) Length, Coaxial Cable	09791CX
STM-120 Lead Assembly, Machine, 12m (40 ft) Length, Coaxial Cable	09796CX

Accessories

21	Fiberglass Positioning Tube With Rack	07219
----	---------------------------------------	-------

***Torches with different cable covers
and connectors available on request.***

EASY FIT

Registered Community Design



Hand Torch Head complete with Handle and parts

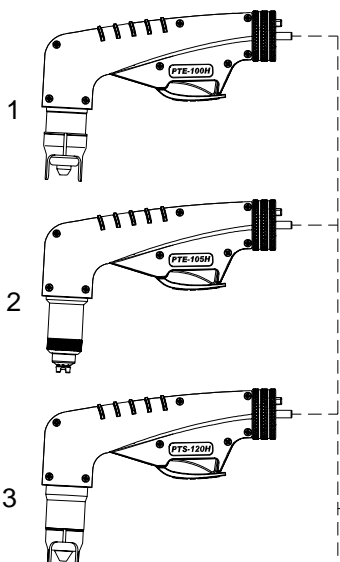

NEW

Machine Torch Head complete with support and parts

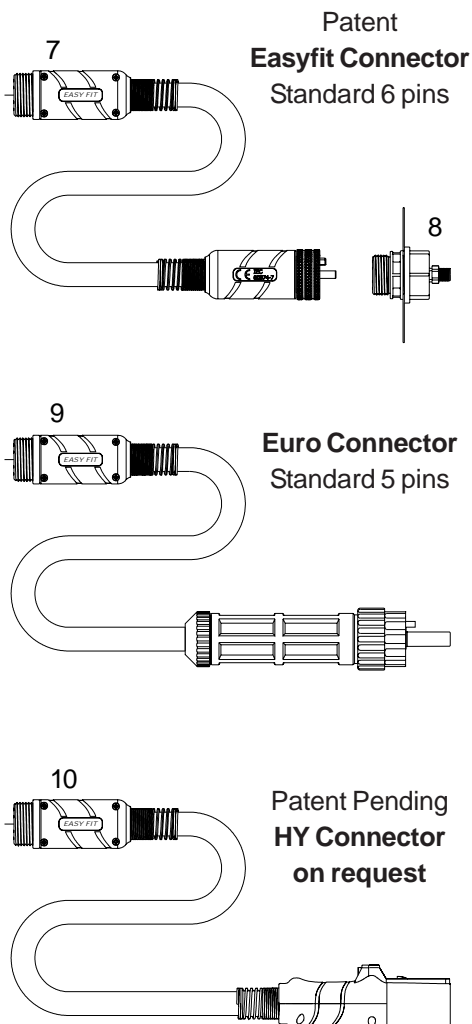
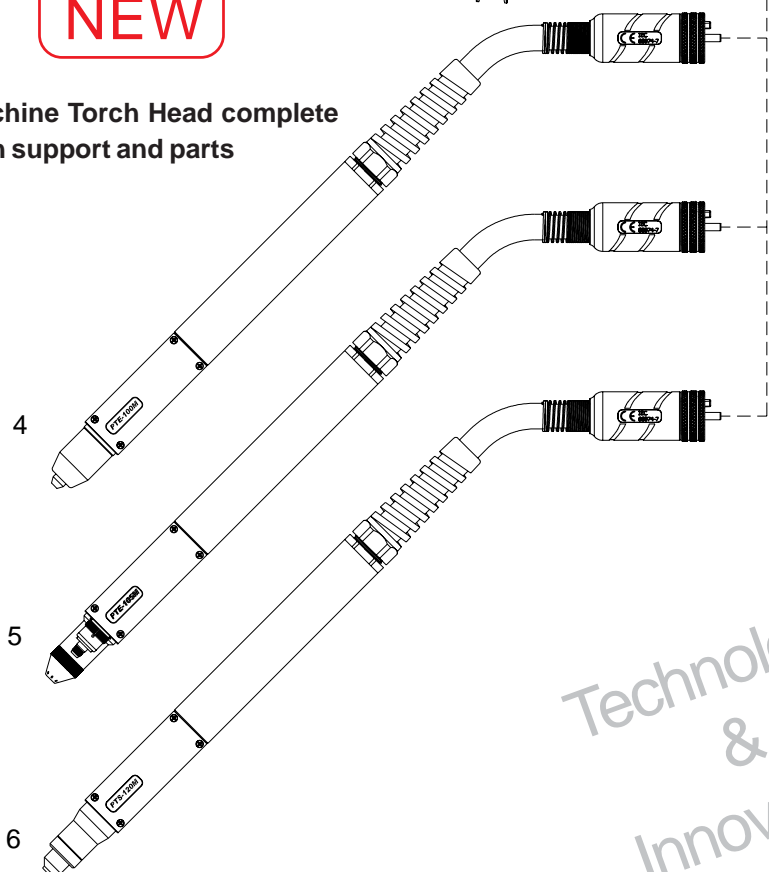

Technology & Innovation
continue ...

EASY FIT**Registered Community Design****Torches and Leads**

<i>Item</i>	<i>Description</i>	<i>Code</i>
1	PTE-100H 75° Hand Torch Head EASY FIT	09701
2	PTE-105H 75° Hand Torch Head EASY FIT	09701P
3	PTS-120H 75° Hand Torch Head EASY FIT	03801
4	PTE-100M 180° Machine Torch Head EASY FIT ,	09711
5	PTE-105M 180° Machine Torch Head EASY FIT	09711P
6	PTS-120M 180° Machine Torch Head EASY FIT	03811
7	Lead Assembly, 6 m (20 ft), Rubber Cable eco , EASY FIT , 6 pins, 125A max	05285
	Lead Assembly, 12m (40 ft), Rubber Cable eco , EASY FIT , 6 pins, 125A max	05287
	Lead Assembly, 6m (20 ft), Coaxial Cable , EASY FIT , 6 pins, 125A max	05285FX
	Lead Assembly, 12m (40 ft), Coaxial Cable , EASY FIT , 6 pins, 125A max	05287FX
8	EASY FIT Central Connection, Machine Side, 6 pins	05265
9	Lead Assembly, 6m (20 ft), Rubber Cable eco , Euro-Connector , 5 pins, 125A max	09781F **
	Lead Assembly, 12m (40 ft), Rubber Cable eco , Euro-Connector , 5 pins, 125A max	09786F **
	Lead Assembly, 6m (20 ft), Coaxial Cable , Euro-Connector , 5 pins, 125A max	09781FX **
	Lead Assembly, 12m (40 ft), Coaxial Cable , Euro-Connector , 5 pins, 125A max	09786FX **

** Connection to the system to be confirmed on the purchase order

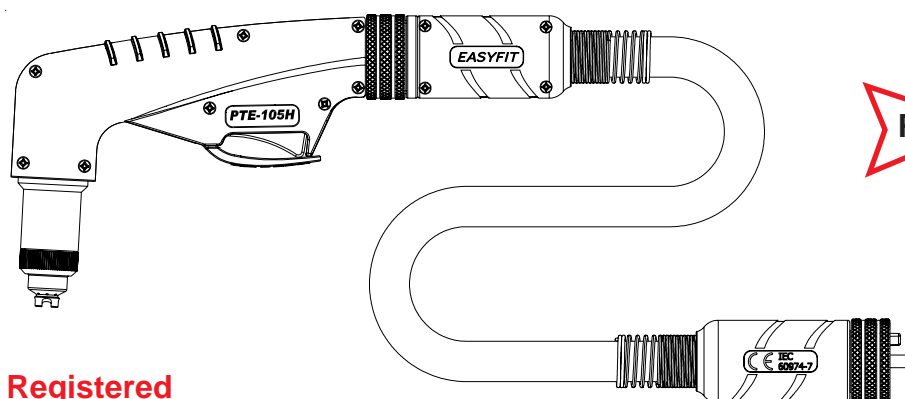
**Registered
Community
Design**

Technical Data

Current: 30-100 Amps
 Duty Cycle: 100 Amps 60%
 Gas: Air/N2
 Gas Pressure: 70-80 PSI (4.5-5.5 bar)
 Gas Flow: 510 SCFH (240 lpm)
 Post Flow Time: 45 sec
 Pilot: Electrode to Tip (18-22A)
 Ignition: Without HF

For the correct operation please use:
 3-Ways Solenoid Valve, inside orifice
 3.5-4.0mm - (0.138-0.157 inches)

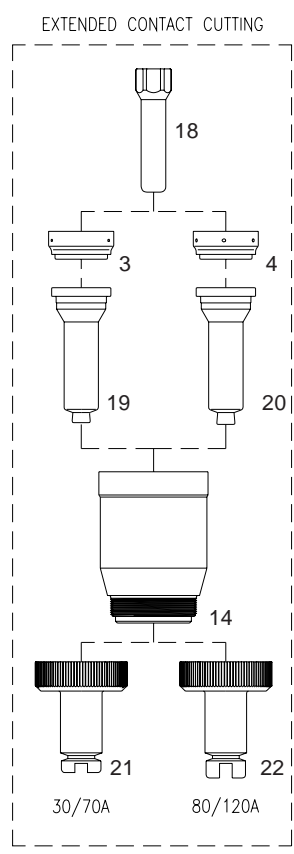
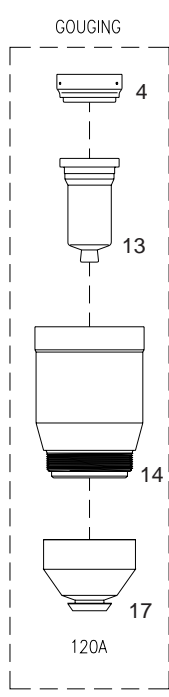
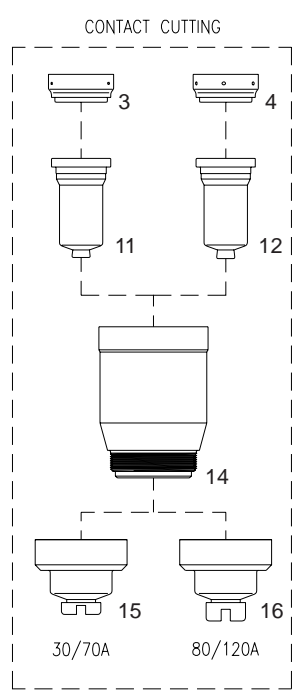
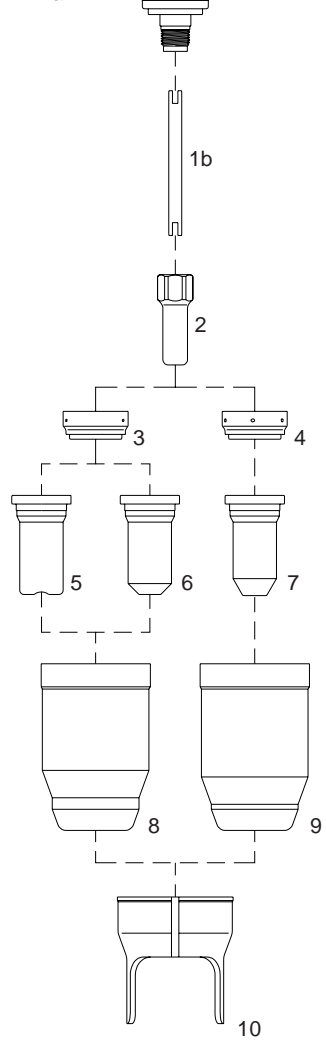
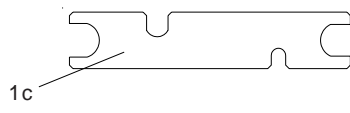
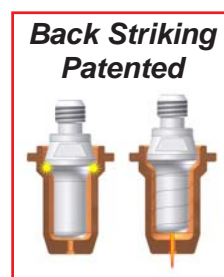
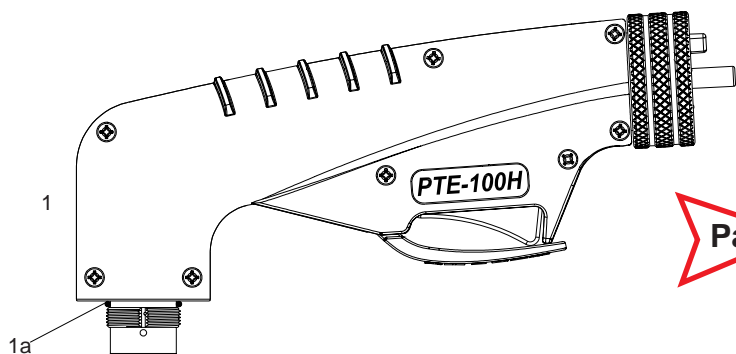

TEC.MO.[®]

PLASMA CUTTING TORCHES

PTE-100H*Air or N₂*

PTE-100H
 ● **Standard Layout**

**Air Filter
 AT-1000**



Bevel Tool
 Patent pending

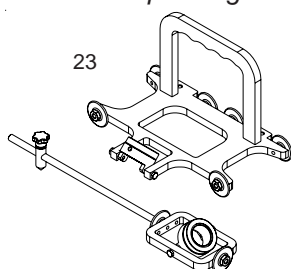

Replacement Parts

Torch parts

Item	Description	Code
1	● PTE-100H Hand torch head EASY FIT , w/ handle & parts.	09701
1a	O-Ring	51190.41
1b	Cooling Tube	09700.48
1c	Wrench for electrode	60368
2	● Electrode, Back Striking	52556
3	Swirl ring, 30-70A	60025
4	● Swirl ring, 80-100A and Gouging	60026
5	Tip, Contact Cutting, \varnothing 0.9, 30-40A, Back Striking	51245.09
6	Tip, Cutting, \varnothing 1.0, 40-50A, Back Striking	51246.10
	Tip, Cutting, \varnothing 1.1, 50-60A, Back Striking	51246.11
	Tip, Cutting, \varnothing 1.2, 60-70A, Back Striking	51246.12
7	Tip, Cutting, \varnothing 1.4, 80-90A, Back Striking	51248.14
	● Tip, Cutting, \varnothing 1.5, 100A, Back Striking	51248.15
8	Retaining Cap, 30-70A	60500
9	● Retaining Cap, 80-100A	60501
10	● Double Pointed Spacer (for use with item. 7 and 8 only)	60444
N/S	● Wrench for electrode	60368

Accessories

Item#	Description	Code #
11	Contact Tip, \varnothing 1.0, 40-50A, Back Striking	51276.10
	Contact Tip, \varnothing 1.1, 50-60A, Back Striking	51276.11
	Contact Tip, \varnothing 1.2, 60-70A, Back Striking	51276.12
12	Contact Tip, \varnothing 1.4, 80-90A, Back Striking	51278.14
	Contact Tip, \varnothing 1.5, 100A, Back Striking	51278.15
13	Tip, Gouging, 100A, Back Striking	51278G.22
14	Shield Cup Body	60502
15	Shield Cap, Hand, 40-70A	60504
16	Shield Cap, Hand, 80-100A	60505
17	Shield Cap, Gouging	60508
18	Extended Electrode	52556L
19	Extended Shielded Tip, \varnothing 1.0, 40-50A,	51276L.10
	Extended Shielded Tip, \varnothing 1.1, 50-60A,	51276L.11
	Extended Shielded Tip, \varnothing 1.2, 60-70A,	51276L.12
20	Extended Shielded Tip, \varnothing 1.4, 80-90A,	51278L.14
	Extended Shielded Tip, \varnothing 1.5, 100A,	51278L.15
21	Extended Shielded Cap, Hand, 40-70A	60504L
22	Extended Shielded Cap, Hand, 80-100A	60505L
N/S	Circle Cutting Attachment	51864
23	BEVEL TOOL	51887

**Registered
 Community
 Design**

**Torches with different cable covers
 and connectors available on request.**

Technical Data

Current: 30-100 Amps
 Duty Cycle: 100 Amps 60%
 Gas: Air/N2
 Gas Pressure: 70-80 PSI (4.5-5.5 bar)
 Gas Flow: 510 SCFH (240 lpm)
 Post Flow Time: 45 sec
 Pilot: Electrode to Tip (18-22A)
 Ignition: Without HF

For the correct operation please use:
 3-Ways Solenoid Valve, inside orifice
 3.5-4.0mm - (0.138-0.157 inches)



NEW

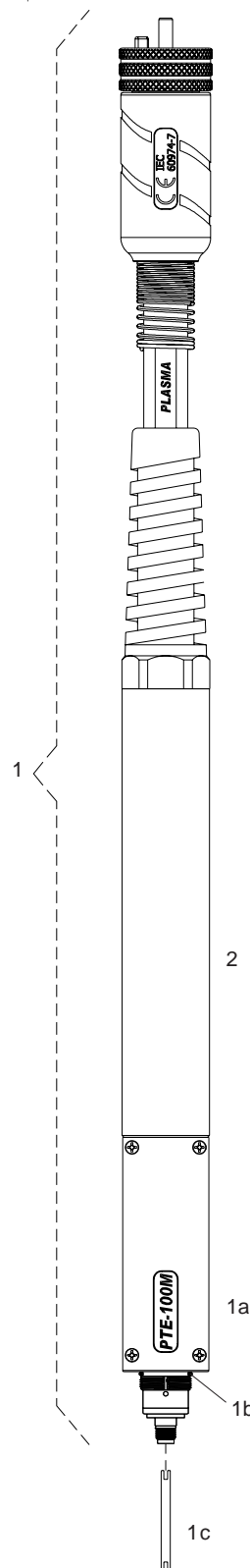
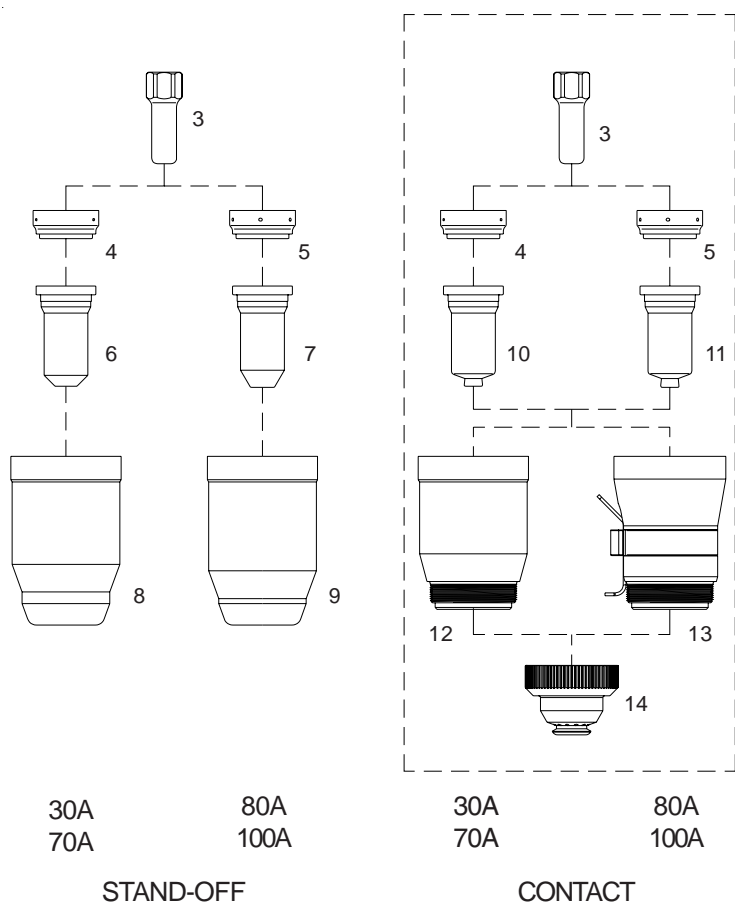
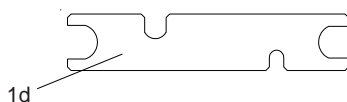

PTE-100M
● **Standard Layout**

Air Filter
AT-1000



Replacement Parts

Torch parts

Item#	Description	Code#
1	● PTE-100M Machine torch head EASY FIT , with tube & parts	09711
1a	● Machine torch head	09710
1b	O-Ring	51190.41
1c	Cooling Tube	09700.48
1d	Wrench for electrode	60368
2	● Fiberglass Positioning Tube	07218
3	● Electrode, Back Striking	52556
4	Swirl ring, 30-70A	60025
5	● Swirl ring, 80-100A	60026
6	Tip, Cutting, \varnothing 1.0, 40-50A, Back Striking	51246.10
	Tip, Cutting, \varnothing 1.1, 50-60A, Back Striking	51246.11
	Tip, Cutting, \varnothing 1.2, 60-70A, Back Striking	51246.12
7	Tip, Cutting, \varnothing 1.4, 80-90A, Back Striking	51248.14
	● Tip, Cutting, \varnothing 1.5, 100A, Back Striking	51248.15
8	Retaining Cap, 30-70A	60500
9	● Retaining Cap, 80-100A	60501
N/S	● Wrench for electrode	60368

Accessories

Item#	Description	Code#
10	Contact Tip, \varnothing 1.0, 40-50A, Back Striking	51276.10
	Contact Tip, \varnothing 1.1, 50-60A, Back Striking	51276.11
	Contact Tip, \varnothing 1.2, 60-70A, Back Striking	51276.12
11	Contact Tip, \varnothing 1.4, 80-90A, Back Striking	51278.14
	Contact Tip, \varnothing 1.5, 100A, Back Striking	51278.15
12	Shield Cup Body	60502
13	Shield Cup Body, OHMIC	60502H
14	Shield Cap, Machine	60506

**Registered
Community
Design**

***Torches with different cable covers
and connectors available on request.***

PLASMA CUTTING TORCHES

Tecnical Data

Current: 30-100 Amps
 Duty Cycle: 100 Amps 60%
 Gas: Air/N2
 Gas Pressure: 70-80 PSI (4.5-5.5 bar)
 Gas Flow: 510 SCFH (240 lpm)
 Post Flow Time: 45 sec
 Pilot: Electrode to Tip (18-22A)
 Ignition: Without HF

For the correct operation please use:
 3-Ways Solenoid Valve, inside orifice
 3.5-4.0mm - (0.138-0.157 inches)

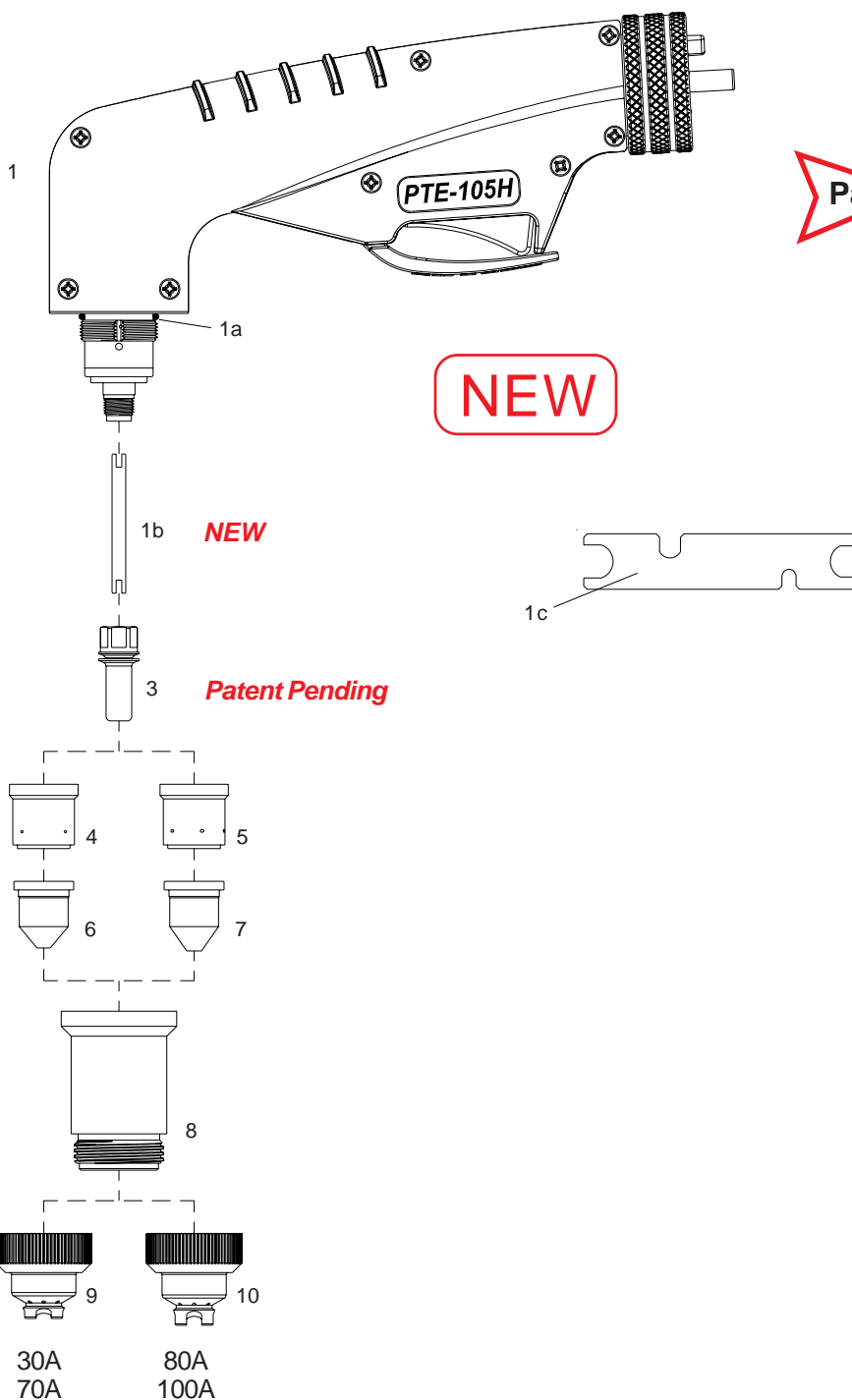

Air or N₂

PTE-105H
 ● **Standard Layout**

Air Filter
AT-1000



Bevel Tool

Patent pending

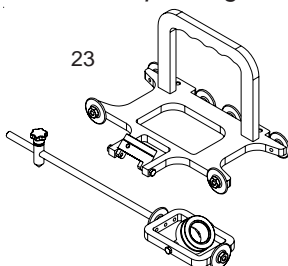

Replacement Parts

Torch parts

Item	Description	Code
1 ●	PTE-105H Hand torch head EASY FIT, w/handle & parts.	09701P
1a	O-Ring	51190.41
1b	Cooling Tube, NEW	09700.62
1c	Wrench for electrode	60368
2 ●	Electrode	52559
3	Swirl ring, 30-70A	60021
4 ●	Swirl ring, 80-100A	60022
5	Tip, Cutting, 40A	51257.09
	Tip, Cutting, 60A	51257.11
6	Tip, Cutting, 80A	51258.13
	● Tip, Cutting, 100A	51258.15
7 ●	Shield Cup Body	60499
8	Shield Cap, Hand, 30-70A	60514
9 ●	Shield Cap, Hand, 80-100A	60515
N/S ●	Wrench for electrode	60368

Accessories

N/S	Circle Cutting Attachment	51865
10	BEVEL TOOL	51880

**Registered
 Community
 Design**

**Torches with different cable covers
 and connectors available on request.**

PLASMA CUTTING TORCHES

Technical Data

Current :	30-100 Amps
Duty Cycle:	100 Amps 60%
Gas:	Air/N2
Gas Pressure:	70-80 PSI (4.5-5.5 bar)
Gas Flow:	510 SCFH (240 lpm)
Post Flow Time:	45 sec
Pilot :	Electrode to Tip (18-22A)
Ignition:	Without HF

For the correct operation please use:
 3-Ways Solenoid Valve, inside orifice
 3.5-4.0mm - (0.138-0.157 inches)



NEW

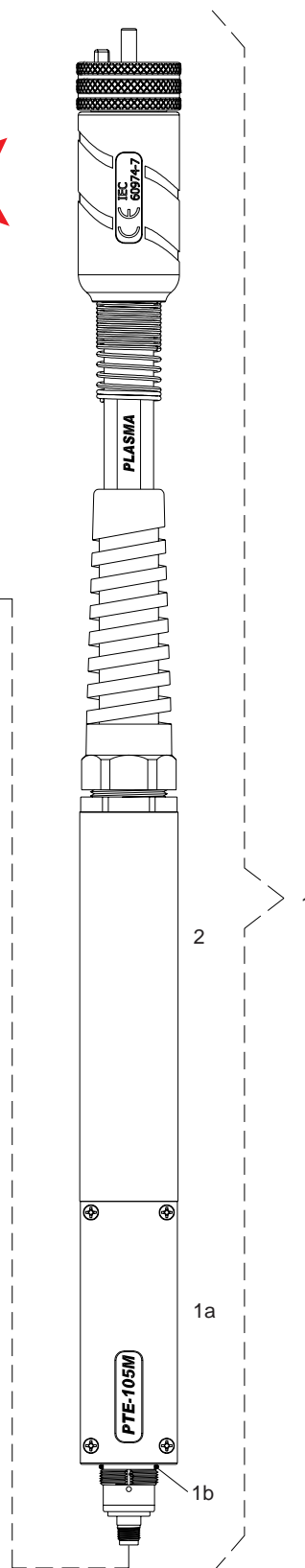
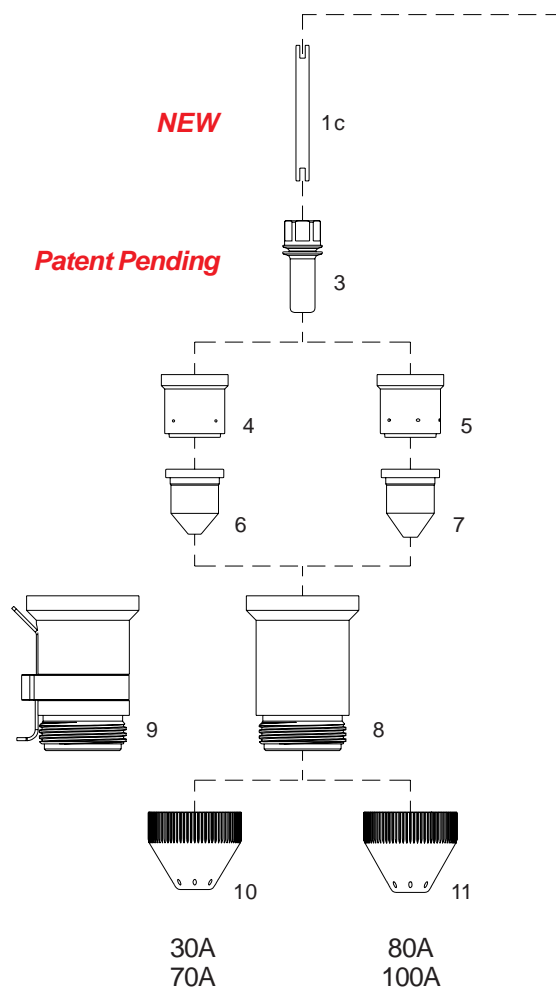
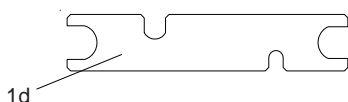

*Air or N₂***PTE-105M**● **Standard Layout**Air Filter
AT-1000**Replacement Parts****Torch parts**

<i>Item</i>	<i>Description</i>	<i>Code</i>
1	● PTE-105M Machine torch head EASY FIT, w/tube & parts	09711P
1a	● Machine torch head	09710P
1b	O-Ring	51190.41
1c	Cooling Tube, NEW	09700.62
1d	Wrench for electrode	60368
2	● Fiberglass Positioning Tube	07218
3	● Electrode	52559
4	Swirl ring, 30-70A	60021
5	● Swirl ring, 80-100A	60022
6	Tip, Cutting, 40A	51257.09
	Tip, Cutting, 60A	51257.11
7	Tip, Cutting, 80A	51258.13
	● Tip, Cutting, 100A	51258.15
8	● Shield Cup Body	60499
9	Shield Cup Body, OHMIC	60499H
10	Shield Cap, Machine, 30-70A	60516
11	● Shield Cap, Machine, 80-100A	60517
N/S	● Wrench for electrode	60368

**Registered
Community
Design**

***Torches with different cable covers
and connectors available on request.***

Technical Data

Current: 40-120 Amps
 Duty Cycle: 120 Amps 60%
 Gas: Air/N2
 Gas Pressure: 70-80 PSI (4.6-5.5 bar)
 Gas Flow: 630 SCFH (295 lpm)
 Post Flow Time: 45 sec
 Pilot: Electrode to Tip (18-22A)
 Ignition: Without HF

For the correct operation please use:
 3-Ways Solenoid Valve, inside orifice
 4.5-5.5mm - (0.178-0.217 inches)

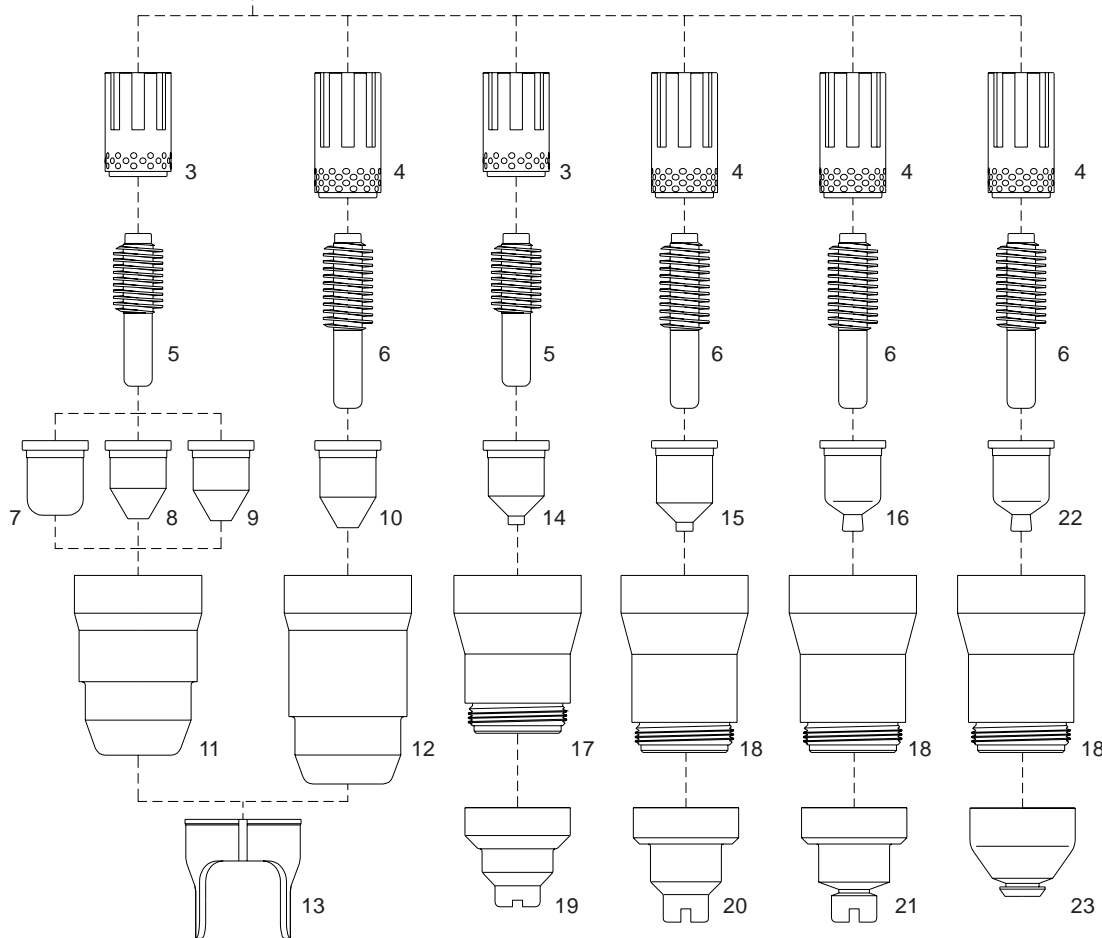
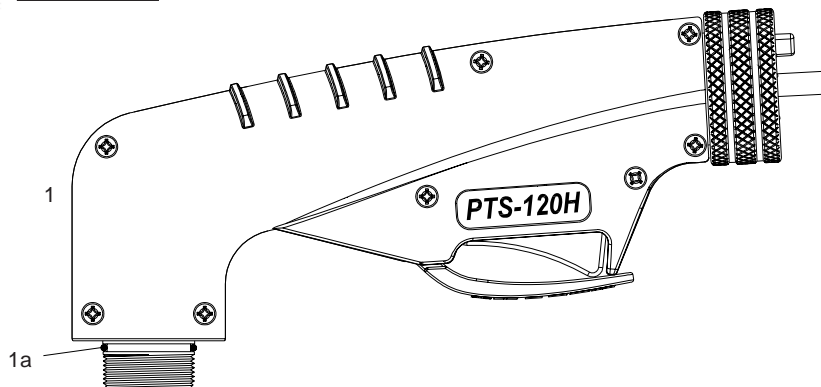

40A
80A

80A
120A

40A
80A

80A
100A

100A
120A

100A
120A

STAND-OFF

CONTACT

GOUGING

PTS-120H
● **Standard Layout**

Air Filter
AT-1000



Bevel Tool
Patent pending

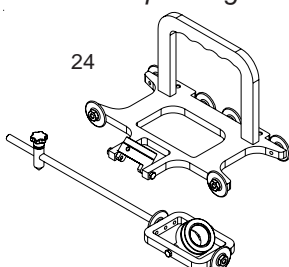

Replacement Parts

Torch parts

Item	Description	Code
1	● PTS-120H Hand torch head EASY FIT , w/ handle & parts.	03801
1a	O-Ring	02800.60
3	Gas Distributor, 40-80A	60043E
	Gas Distributor, 40-80A Maximum Life	60043
4	● Gas Distributor, 80-120A	60044E
	Gas Distributor, 80-120A Maximum Life	60044
5	Electrode, 40-80A	52675
6	● Electrode, 80-120A	52676
7	Tip, Cutting, 40A	51402
8	Tip, Cutting, 60A	51403
9	Tip, Cutting, 80A	51404
10	Tip, Cutting, 100A	51408
	Tip, Cutting, 120A	51408T
11	Retaining Cap, 40-80A	60493
12	● Retaining Cap, 80-120A	60494
13	● Double Pointed Spacer	60434
14	Contact Tip, Cutting, 40A	51405.10
	Contact Tip, Cutting, 60A	51405.12
	Contact Tip, Cutting, 80A	51405.14
15	Contact Tip, Cutting, 100A	51406
16	Contact Tip, Cutting, 120A	51406T
17	Shield Cup Body, 40-80A	60495
18	Shield Cup Body, 80-120A	60496
19	Shield Cap, Hand, 40-80A	51981/TD
20	Shield Cap, Hand, 80-100A	51983/TD
21	Shield Cap, Hand, 100-120A	51988
22	Contact Tip, Gouging, 100-120A	51409.24
23	Shield Cap, Gouging, 100-120A	51989G

Accessories

N/S	Circle Cutting Attachment	51865
24	BEVEL TOOL	51880

**Registered
Community
Design**

**Torches with different cable covers
and connectors available on request.**

PLASMA CUTTING TORCHES

Technical Data

Current: 40-120 Amps
 Duty Cycle: 120 Amps 60%
 Gas: Air/N₂
 Gas Pressure: 70-80 PSI (4.6-5.5 bar)
 Gas Flow: 630 SCFH (295 lpm)
 Post Flow Time: 45 sec
 Pilot: Electrode to Tip (18-22A)
 Ignition: Without HF

For the correct operation please use:
 3-Ways Solenoid Valve, inside orifice
 4.5-5.5mm - (0.178-0.217 inches)

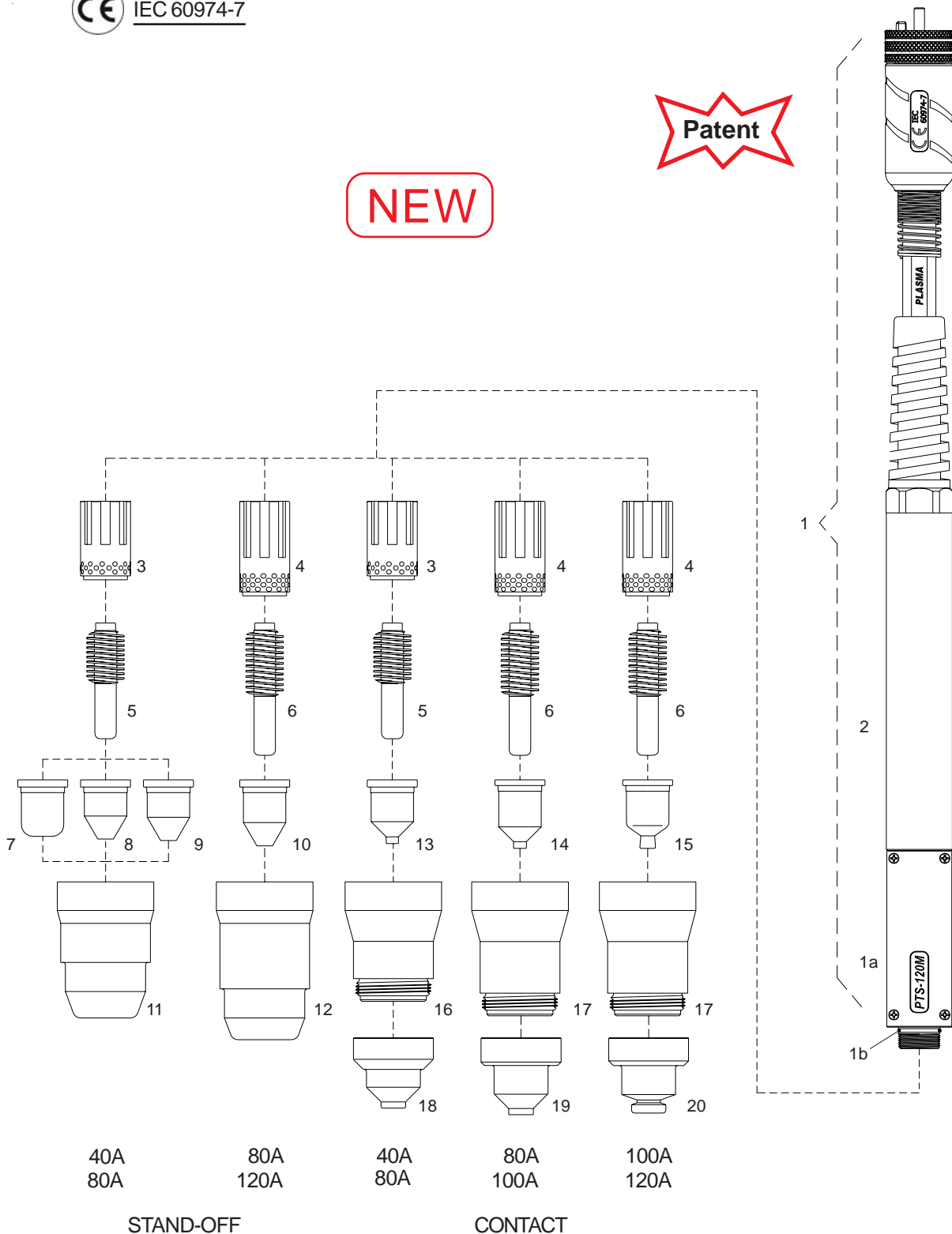

*Air or N₂***PTS-120M**● **Standard Layout****Air Filter
AT-1000****Replacement Parts****Torch parts**

<i>Item</i>	<i>Description</i>	<i>Code</i>
1	● PTS-120M Machine Torch Head EASY FIT, w/positioning tube & parts	03811
1a	● Machine Torch Head	03810
1b	O-Ring	02800.60
2	● Fiberglass Positioning Tube	07218
3	Gas Distributor, 40-80A	60043E
	Gas Distributor, 40-80A Maximum Life	60043
4	● Gas Distributor, 80-120A	60044E
	Gas Distributor, 80-120A Maximum Life	60044
5	Electrode, 40-80A	52675
6	● Electrode, 80-120A	52676
7	Tip, Cutting, 40A	51402
8	Tip, Cutting, 60A	51403
9	Tip, Cutting, 80A	51404
10	Tip, Cutting, 100A	51408
	Tip, Cutting, 120A	51408T
11	Retaining Cap, 40-80A	60493
12	Retaining Cap, 80-120A	60494
13	Contact Tip, Cutting, 40A	51405.10
	Contact Tip, Cutting, 60A	51405.12
	Contact Tip, Cutting, 80A	51405.14
14	Contact Tip, Cutting, 100A	51406
15	● Contact Tip, Cutting, 120A	51406T
16	Shield Cup Body, 40-80A	60495
17	● Shield Cup Body, 80-120A	60496
18	Shield Cap, Machine, 40-80A	51982/TD
19	Shield Cap, Machine, 80-100A	51984/TD
20	● Shield Cap, Machine, 100-120A	51989

**Registered
Community
Design**

***Torches with different cable covers
and connectors available on request.***

EASY FIT Connector

Registered Community Design

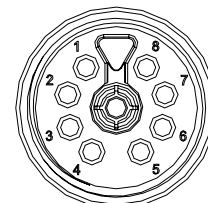
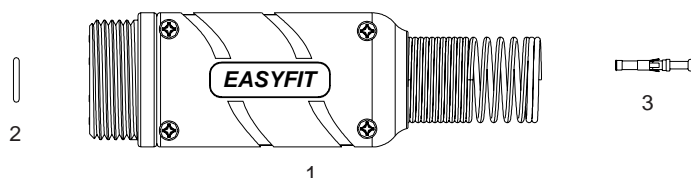
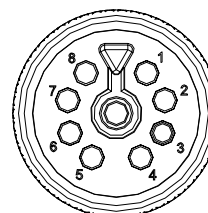
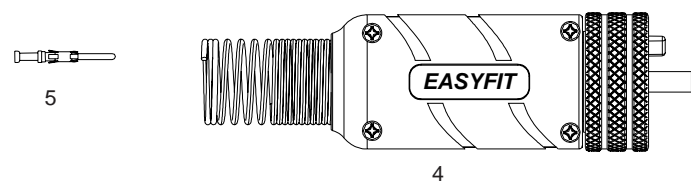
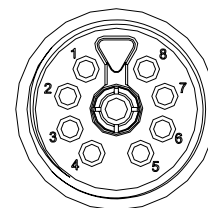
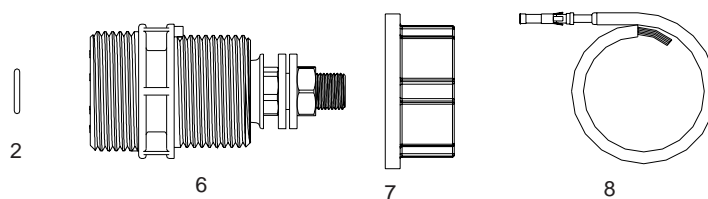
EASY FIT
PatentTorch side
FEMALETorch side
MALEMachine side
FEMALE

Item	Description	Code
1	Complete KIT Easyfit Female - for cables with 1/8-Gas connection	05266
	Complete KIT Easyfit Female - for cables with crimped connection	05266RPT
2	O-Ring - (conf.20 pcs)	20850.41
3	Contact pin female - (conf.10 pcs)	05265.45
4	Complete KIT Easyfit Male - for cables with 1/8-Gas connection	05260
	Complete KIT Easyfit Male - for cables with crimped connection	05261RPT
5	Contact pin male - (conf.10 pcs)	05260.45
6	Machine connector Easyfit (standard connection 6 pins)	05265
	Machine connector Easyfit (connection 7 pins)	05265-7
	Machine connector Easyfit (connection 8 pins)	05265-8
7	Hexagonal Nut	04265.41
8	Contact pin, BLACK lead, 0.75mm ² x 600mm	04265.21
	Contact pin, RED lead, 0.75mm ² x 600mm	04265.22
	Contact pin, BLUE lead, 0.75mm ² x 600mm	04265.23
	Contact pin, BROWN lead, 0.75mm ² x 600mm	04265.24
	Contact pin, WHITE lead, 0.75mm ² x 600mm	04265.25

TEC.MO.[®]

PLASMA CUTTING TORCHES

AIR FILTER AT1000

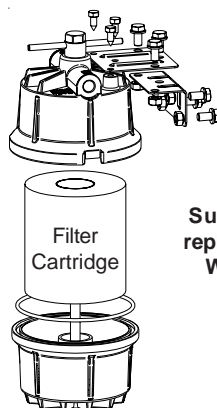

**Suggested
replacement:
WEEKLY**

Air Filter Complete Code: 50500

Packaging:

Air Filter AT1000

Code: 50500-12

Carton Box: 12 Filters

Dimensions: 11" x 16.5" x h. 17.3"
(cm 28 x 42 x h. 44)

Weight: 43 lbs (19.5 kg)

Filter Cartridge

Code: 50505-8

Carton Box: 8 Cartridges

Dimensions: 8.58" x 8.58" x h. 9.61"
(cm 21.8 x 21.8 x h. 24.4)

Weight: 4.2 lbs (1.9 kg)

Code: 50505-48

Master Box: 8x6=48 Cartridges

Dimensions: 17.72" x 26.38" x h. 10.43"
(cm 45 x 67 x h. 26.5)

Weight: 26.7 lbs (12.1 kg)

"AT 1000" is the perfect solution to the problems created by the contamination of the compressed air used in many plasma cutting systems.

It eliminates "sputter" caused by moisture and oil from compressed air lines.

It extends the electrode and nozzle life, with obvious benefits to the cut quality.

Designed to remove aerosol oil and moisture, "AT 1000" is a real benefit, entrapping particles as small as .01 microns inches.

With "AT 1000" torches last longer. Without this filter, at the end of this cutting session, inside the torch and torch head you have left condensed moisture, that can cause a short-circuit, with consequent rise of costs coming from the replacement of the torch head and the needed time to realize this operation.

"AT 1000" can filter up to 1250 liters a minute without reduction in pressure.

It's recommended to replace the filter cartridge every 5 to 7 days (max).

It's also very suitable for painters and use of pneumatic tools.

Our excellent knowhow in the production of plasma cutting torches and the consequent problems of air contaminant brought us to create the "AT 1000" being very effective and important for users of plasma cutting systems.

BEVEL TOOL



Code	Description
51880	TEC.MO. [®] PT40, PT60, PT80, PT105 Plus, ST-120, PTE-105H Plus , PTS-120H
51887	TEC.MO. [®] PT-100, PTE-100H

TEC.MO.
=

Quality
Technology
Innovation